

# MITSUBISHI GRAPHIC ARTS SYSTEM

PF-60

PF-60H

PF-110H

---

# Table of Contents

---

<b>1 . Introduction</b> .....	<b>1</b>	
-------------------------------	----------	--

<b>2 . Precautions</b> .....	<b>3</b>	
------------------------------	----------	--

<b>3 . Parts Description</b> .....	<b>4</b>	
------------------------------------	----------	--

<b>4 . Preparation</b> .....	<b>6</b>	
------------------------------	----------	--

<b>5 . Setting the Presets to Determine Bend Sizes</b> .....	<b>8</b>	
--	----------	--

<b>6 . Operation Procedure for Single Bend</b> .....	<b>10</b>	
--	-----------	--

<b>7 . Operation Procedure for Double Bends and Two Step Bends</b> .....	<b>12</b>	
--	-----------	--

<b>8 . Adjusting the Plate Bend Angle</b> .....	<b>13</b>	
---	-----------	--

# 1. Introduction

## 1) Outline

The Silver Master plate formers, PF-60, PF-60H and PF-110H are machines designed for use with SILVER MASTER and SILVER DIGIPLATE polyester based direct to plate materials.

This innovative plate bending machine allows for very precise bends to be made in polyester film based printing plates. The machine can be used in conjunction with business forms presses as well as commercial web presses, and is very easy to operate.

Please read this operation manual thoroughly before use in order achieve maximum productin, and efficiency. Correct use of this equipment will also prolong the life of the machine.

For information on how to use SILVER MASTER materials or SILVER DIGIPLATE materials on press, please see "SILVER MASTER Technical Guide" or "SILVER DIGIPLATE Technical Guide".

## 2) Main Specifications

ITEM	PF-60, 60H	PF-110H
Forming Method	Blade actuated. Heat and pressure method.	Blade actuated. Heat and pressure method.
Register System	Edge contact method. * Three presets can be set.	Edge contact method. * Three presets can be set.
Plate Materials Used	Silver Master or Silver Digi plate polyester based plates.	Silver Master or Silver Digi plate polyester based plates.
Effective Width	254-600mm (10 to 23 5/8")	185-1100mm (7 9/32 to 43 5/16")
Effective Thickness	0.125-0.20mm (.005 to .008")	0.125-0.20mm (.005 to .008")
Eff.Bend Size	3-35mm (1/8 to 1 3/8")	3-35mm (1/8 to 1 3/8")
Bend Accuracy	± 0.1mm ( ± .004") or less	± 0.1mm ( ± .004") or less
Dimensions	710 × 900 × 970mm (28.0 × 35.4 × 38.2")	1210 × 900 × 970mm (47.6 × 35.4 × 38.2")
Weight	70kg (154 LBS)	140kg (308 LBS)
Electric Req.	115-120V 1KW or 220-240V 1KW	115-120V 1KW or 220-240V 1KW

※ PF-60 needs no power supply

## 2. Precautions

- \* Do not open or remove the plexiglass cover unless absolutely necessary.
- \* Do not stick your fingers under plate insertion cover.
- \* If the cover must be opened, always turn off the power before opening.  
The pressure contacting plate remains hot for a period of time after the power is shut off. (PF-60H, 110H)
- \* Make sure the electrical connections are correct and that there is proper grounding. (PF-60H, 110H)

## 3. Parts Description

### 1) General View

- 1 Plate Stop Changing Handle
- 2 Setting Lever
- 3 Cover
- 4 Bending Handle
- 5 Table
- 6 Foot Lever

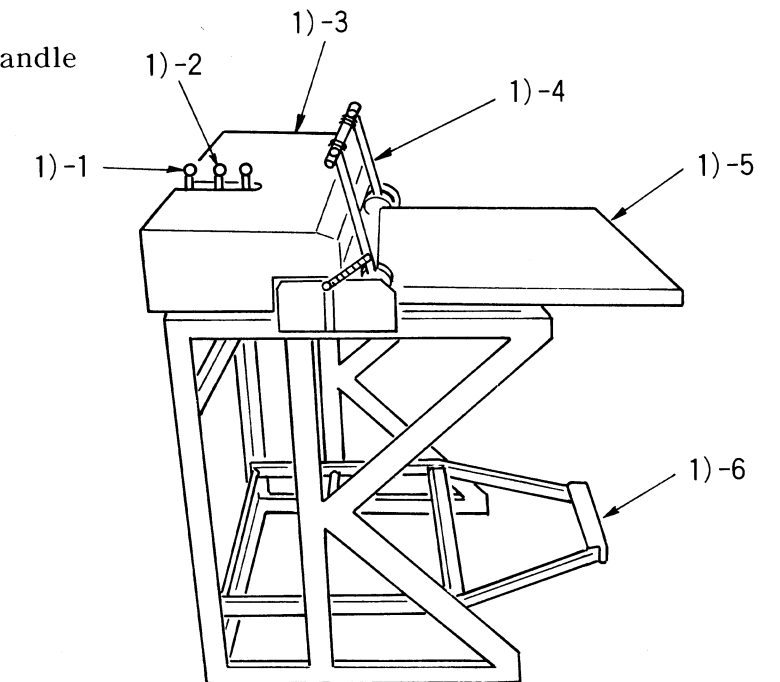

### 2) Plate Stop Section

- 1 Plate Stop
- 2 Plate Stop Parallel Adjustment Nuts

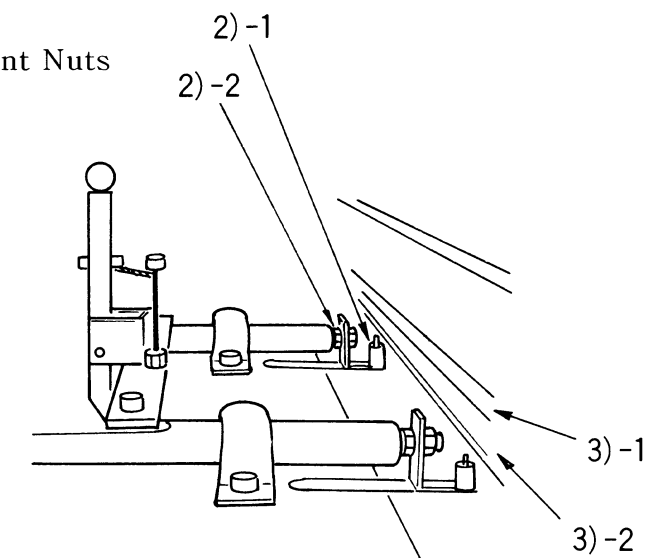

### 3) Blade Section

- 1 Blade
- 2 Pressure Plate

#### 4) Preset Section

- 1 Preset
- 2 Preset Lock Nut
- 3 Scale

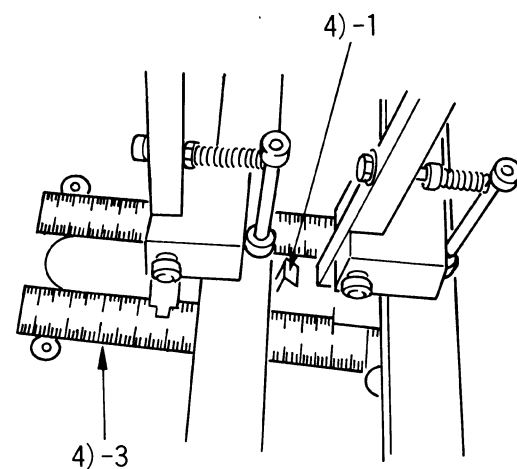
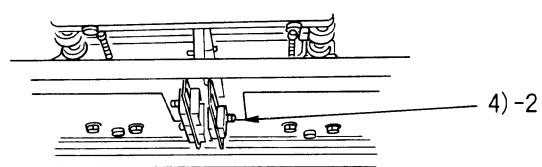

#### 5) Heater Control Box

- 1 Main Switch
- 2 Main Power ON Pilot Lamp (Red)
- 3 Heater Power ON Pilot Lamp (Green)
- 4 Temperature Display
- 5 Set Temperature Display
- 6 Controlled Output Power (Out) Pilot Lamp (Red)
- 7 Set Value Input Key (indicated by **SET**)
- 8 Set Digit Change Key (Indicated by ◀)
- 9 Minus Setting Change Key (Indicated by ▼)
- 10 Plus Setting Change Key (Indicated by ▶)

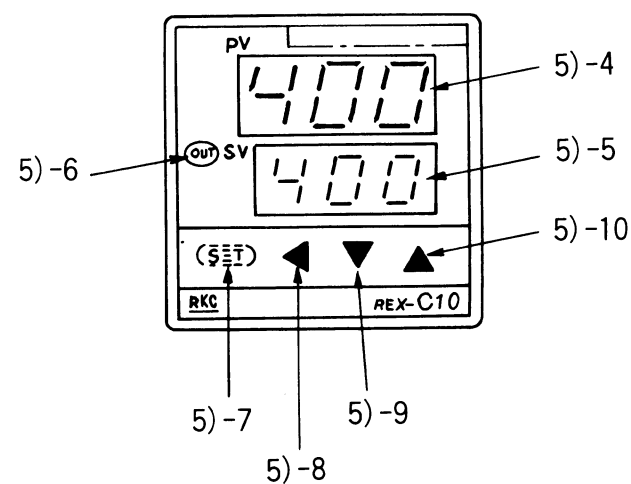
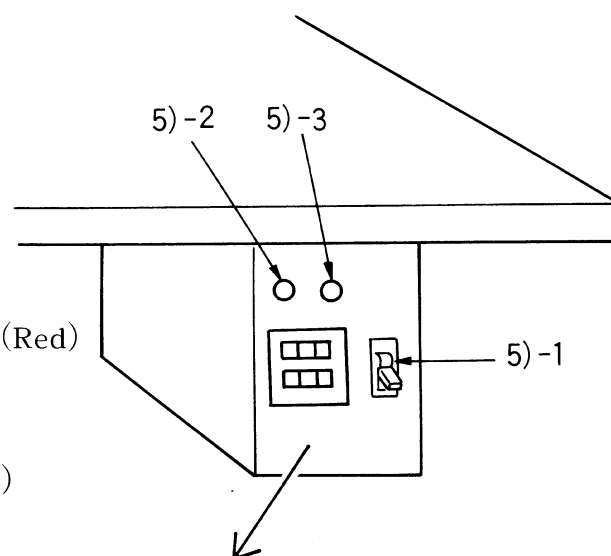

### 4. Preparation

#### 1) Preparation of the plate

- \* Cut the plate to the correct size for the press (including bends) .
- \* Cut the plate in register with the image.
- \* Make sure the edges of the plate are cut straight.

#### 2) Setting the heater (Only PF- 60H, PF-110H)

- (1) Insert the plug into the outlet.115-120 volts. (or 220-240 volts.)
- (2) Turn the main switch ON.
- (3) Check that the set temperature is correct.
- (4) Check that the Main Power ON pilot lamp, and that the Heater Power ON pilot lamp are lit.  
(The heater power on pilot lamp blinks when the heater is heating. This is normal) .
- (5) The heater is ready when the temperature display value reaches the set temperature value, and the Heater Power ON pilot lamp is constantly on.

\* Note 1

The temperature of the unit is set at the factory to 60°C (140°F) . At this temperature plate bends can be performed easily, however, adjustment is possible if a sharper bend is required.

Usually an angle tends to become sharper at higher temperatures, and more obtuse at lower temperatures.This will differ from press to press, a certain amount of trial and error will determine what is best for your particular situation.

As a safety precaution never set the temperature over 100°C (212°F) .

If you have the following problems, stop operating immediately and call the service personnel of the sales agency :

- The main power pilot lamp is not lighted.
- The heater power pilot lamp is not lighted.
- The pressure plate does not become hot when the main power switch is turned on.

### 3) To Set the temperature to 60°C (140°F)

- (1) Press the **SET** key

One digit of the display will remain on, and the others will blink.

- (2) The digit which is on solid can be changed by using the up and down arrows.

Which digit is blinking is changed by the **◀** button.

- (3) Using these buttons make the top display read 060 (or 140) or whatever temp you have decided to use.

- (4) Press the **SET** key

(When all the positions are solid "ON", the input of the set values is complete).

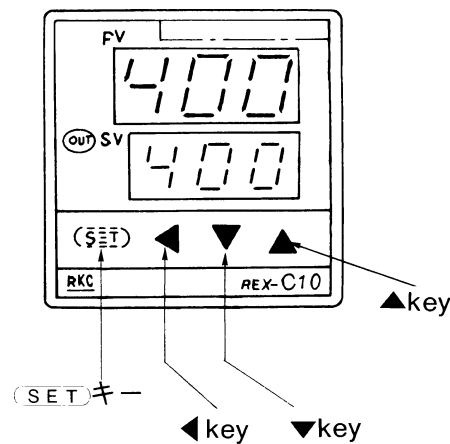

## 5. Setting the Bend Dimensions

\* Before proceeding to the operation of the plate bender the prestops must be set correctly.

\* To make it easy change the dimensions of the bends being made a stopper position preset mechanism has been provided. Using this mechanism the dimension of the bend you wish to make can be changed quickly. This allows you to accomplish the needed bend whether it is a side gripper bend, a double bend or whatever you may need.

### 1) How to set the plate bending dimension stoppers.

	Operation (Key Points)
1	Loosen the lock nut of the stopper preset with a hex wrench (provided). Once the stopper is freed it can be slid along the scale.
2	Slide the stopper preset along the scale until it reaches the setting you have decided on. Tighten the lock nut so it is secured at the location you desire.
3	Perform a test bend. (see operation section)
4	Measure the bend. A trial and error process may be necessary until the operator gets used to the setting process.

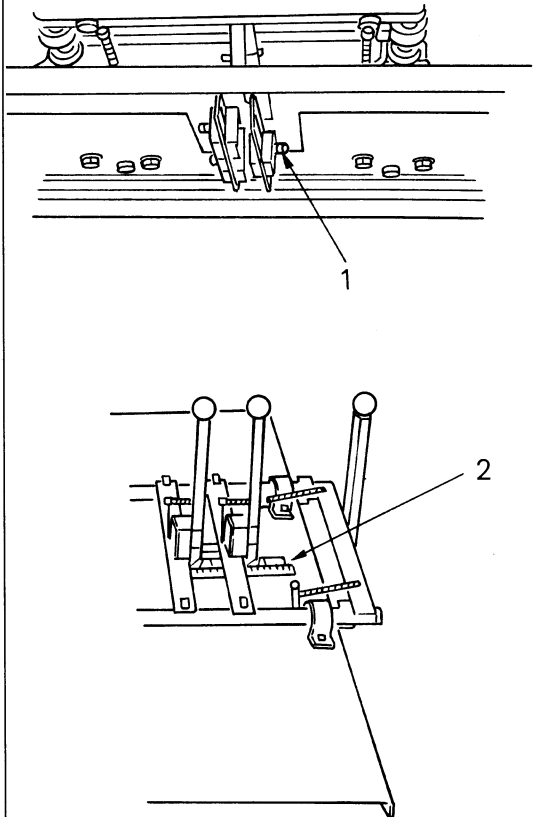

## 6. Operation Procedure for Single Bend

- 2) There are two stopper levers, in combination with the three stopper presets, a variety of bends can be achieved. The best combinations can be achieved when you know the bend dimensions you will need. When two bends are close together in size it may be difficult to use the same lever for each.

For example when both a 10 mm bend and an 11 mm bend are needed a different stopper lever must be used for each, and so the preset will not be 1 mm apart, but will be in very different positions. To aid with this stopper presets can be mounted on both side of the adjusting channel (see diagram).

Example: in the case of the following plate forming specifications...

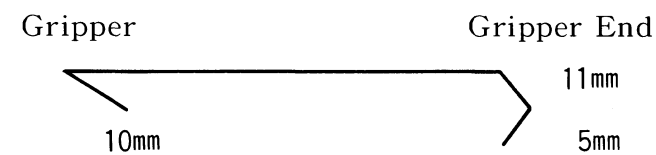

Set gripper margin 11 mm to ① on scale  
 Set outside margin 10 mm to ② on scale  
 Set outside margin 5 mm to ③ on scale

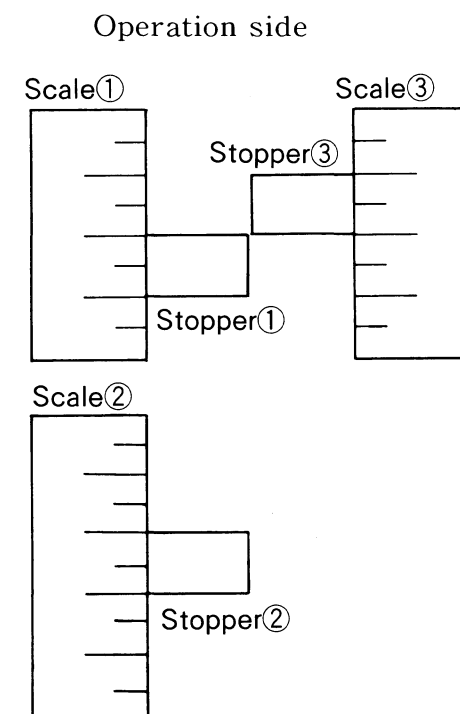

Operation (Key Points)	
1	Using the adjusting handle, the furthest plastic Knob to the rear, move the stopper assembly until the proper lever and preset are lined up. (match the arrow mark of the set lever to the mark on the cover)
2	Place the plate on the table with the emulsion (Image) side down.
3	Move the plate gently and insert it through the plate insertion slit. Move the plate until the edges are in close contact with the right and left stoppers. (Move the plate gently so that the plate surface is not scratched.)
4	Securing the plate gently with your hands, step on the foot lever and depress it as far as it will go.
5	Let the foot lever up.

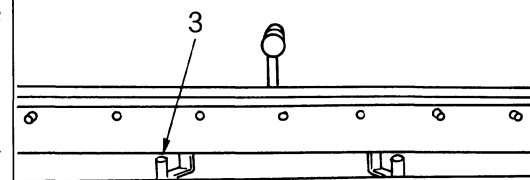
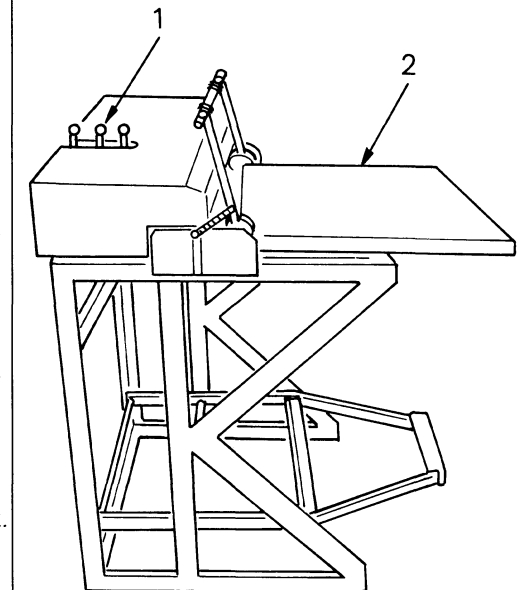

## 7. Operation Procedure for Double Bends and Two Step Bends

Operation (Key Points)	
6	Push down on the plate bending lever, applying firm pressure for 3-5 seconds.
7	Return the plate bending lever to the original position.
8	Snap the plate out with a quick gentle movement.
9	Follow this procedure for each bend you require.

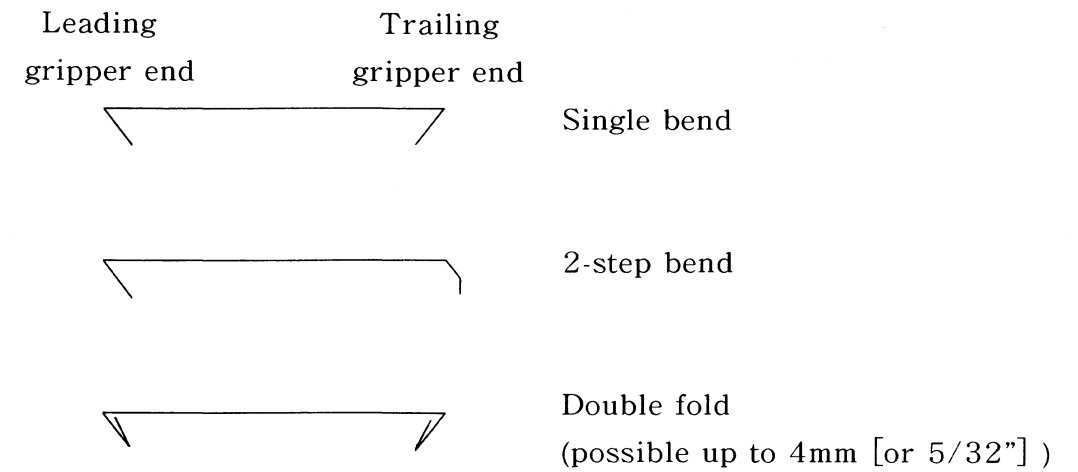
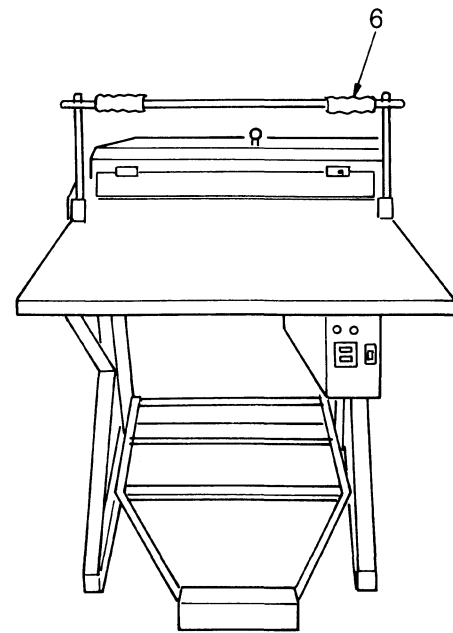

The Silver Master plate former can bend the plate to the above shapes. Choose the type of fold best suited to the specifications of the web offset press used. Note, however, that plates that have been merely bent at the Silver Master plate former cannot sometimes be secured sufficiently due to plate thickness and other physical factors depending on the type of web offset press. If necessary, load using a double fold.

Operation (Key Points)	
1	Make the first bend using the procedure above.
2	Adjust the stoppers for the second bend dimension.
3	Place the bent edge against the stoppers.
4	Following 2)through 8)above make the second bend.

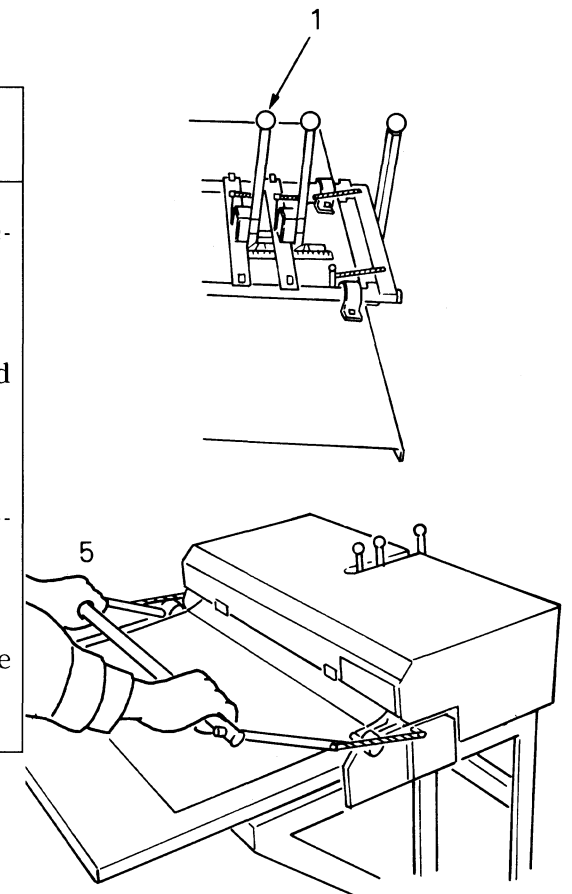



## 8. Adjusting the Angle of Bend

---

Please consider the following, and set the plate bending parameters before use.

### 1) Adjusting the plate contact time.

\* The shorter the pressure contact time, less sharp (the more obtuse) bend angle will be.

The longer the pressure contact time, the sharper (more acute) the angle. However, the limit for this pressure contact is 20 seconds, Beyond this time, few changes are apparent.

\* Set the contact time as to be practical with respect to work flow.

### 2) Adjusting pressure contacting force.

If the force during pressure contact is weak, the plate bend will not be sharp.

If the force is strong, the plate bend will fold back onto the plate itself.

### 3) Adjusting the Pressure Contact Temperature

\* The lower the heater temperature, the less sharp the bend angle.

The higher the temperature, the more acute the angle.

Do not use a temperature over 100°C (212°F) for safety reasons.
---

# MITSUBISHI PAPER MILLS LIMITED

Head office: Shin-Nisseki Bldg., 7th Floor  
No. 4-2, Marunouchi 3 chome, Chiyoda-ku, Tokyo, Japan  
Tel. Tokyo(03)3213-3742

Mitsubishi Paper International, Inc  
601 Midland Avenue, Rye Plaza, Rye, N Y 10580 U.S A      Tel 914-921-4000  
Mitsubishi Paper GmbH  
Kennedydamm 19 4000 Dusseldorf 30 F R Germany      Tel 211-4397-215

---