



SILVER MASTER  
CP-50SII

---

SERVICE MANUAL

---

# CONTENTS

1. Introduction .....	1
2. Specifications .....	2
3. External Dimensions .....	3
4. Processing Path .....	3
5. Installation Procedure .....	4
Installation requirements .....	4
Packing list .....	5
Main body installation .....	6
Level check .....	6
Cutter installation .....	7
Solution preparation .....	7
Power connection .....	7
Inspection and adjustment .....	8

## Mechanical System

1. Optical System Check and Adjustment .....	11
Check and adjustment .....	11
Distortion/magnification check and adjustment .....	12
Focus check .....	13
Magnification check .....	14
2. Mirror Replacement .....	15
3. Thermal Fuse Replacement .....	16
4. Drive Belt Replacement .....	18
5. Copy Board Contact Pad Replacement .....	19
6. Original Positioning Sheet Replacement .....	20
7. Copy Glass Replacement .....	21
8. Halogen Lamp Replacement .....	22
9. Lubrication .....	23
10. Copy Glass Cleaning .....	24

# Electrical System

<b>1. Distribution Board Function Check</b> .....	27
Installation site power voltage check .....	27
CPU board power supply voltage check .....	27
Fuse function .....	28
<b>2. Troubleshooting</b> .....	29
Checking method .....	29
Trouble-check table .....	31
Timing chart .....	32
<b>3. Wiring Diagram</b>	

# 1. Introduction

This manual is intended to be used for after-sale service of the CP-50SII. For operation of this camera, handling of the master, solutions, etc., refer to the CP-50SII Operation Manual and Technical Guide.

Please note that specifications may be changed, and modifications to units in production may occur, without notice.

When ordering parts or requesting explanation/information, please be sure to give the information shown below, as well as referring to the parts list.

- \* Model                   CP-50SII
- \* Serial No.
- \* Part No. and name
- \* Quantity required
- \* Delivery date

Publication or duplication of this manual is prohibited.

## 2. Specifications

No.	Item	Specification
1	Master	Roll qty.: 1; SLM-RII, SLM-F175, SLM-F175CD, SLM-F100
2	Effective image size	11" X 16 15/16" (27.9 X 43.0 cm)
3	Max. image size	11 1/4" X 18 15/16" (28.6 X 48.1 cm)
4	Max. original backing size	15 9/16" X 21 21/32" (39.5 X 55.0 cm)
5	Master width	8 21/32" (22.0 cm), 9" (22.9 cm), 10" (25.4 cm), 11" (27.9 cm), 11 1/4" (28.6 cm)
6	Master cut length	14 19/32" ~ 18 15/16" (37.0 ~ 48.1 cm)
7	Master end detection	Indicator lamp
8	Exposure method	Synchronized original and master movement, slit exposure
9	Light source	Halogen lamp (1) (80V-600W)
10	Magnification	100% (1:1)
11	Lens	f=150 mm (fixed aperture)
12	Cutter	Slide-cut type
13	Original placement	Original, face-down
14	Exposure control	Analog illumination control, 1~23
15	Control panel	Push button type, "START OK" displayed (independently of solution temperature)
16	Film processor	Immersion type, developer: 3.0 ℓ, stabilizer: 2.7 ℓ
17	Replenisher tank	Level replenishment type, developer : 0.5 ℓ stabilizer: 0.5 ℓ
18	Solution temperature control	84.2°F ± 5.4°F (29°C ± 3)
19	Initial master-process time	1 min. 8 sec. (60 Hz), 18 15/16" (48.1 cm) feed length
20	Cycle time	46 sec. (60 Hz), 18 15/16" (48.1 cm) feed length
21	Power	1 φ 115V 1.2kW
22	Dimensions (W X D X H)	99 X 59 X 42 cm
23	Weight (without solutions)	70 kg
24	Operating conditions	Temperature: 50~86°F (10 ~30°C), humidity: 40~70%

### 3. External Dimensions

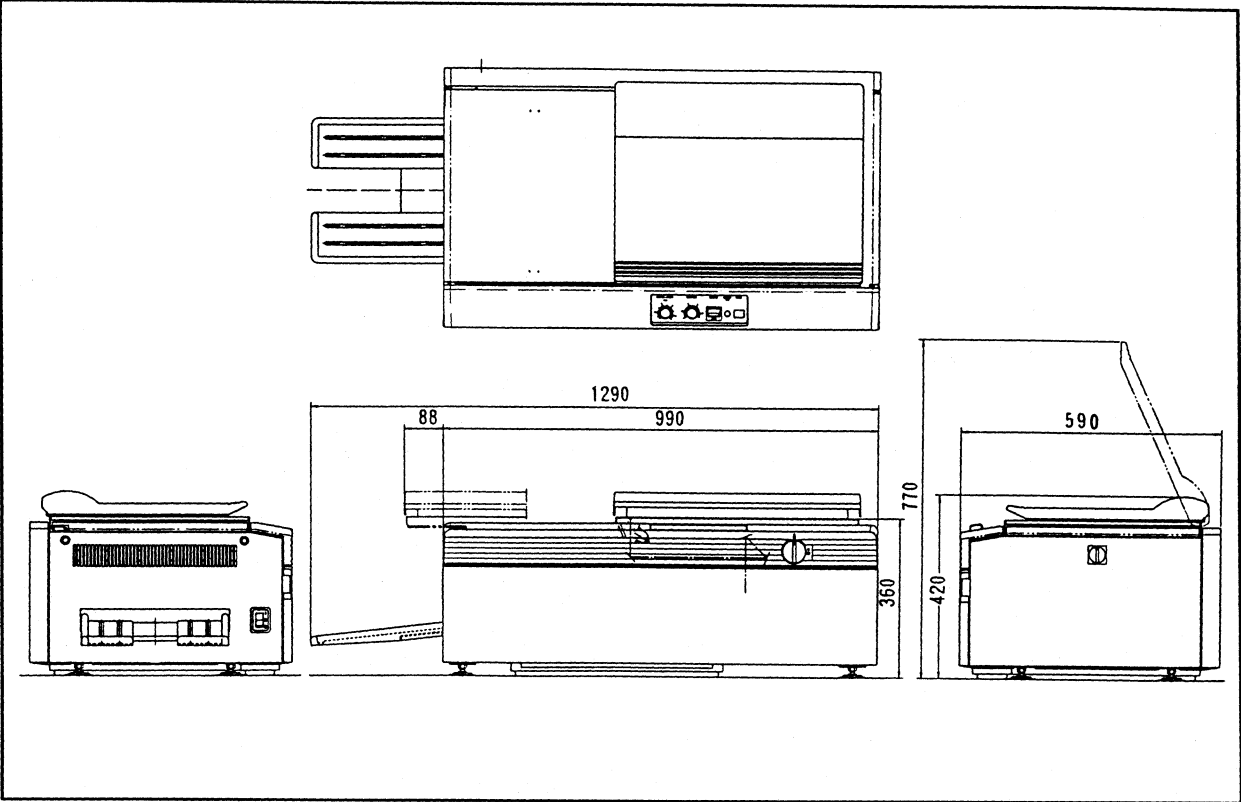

### 4. Processing Path

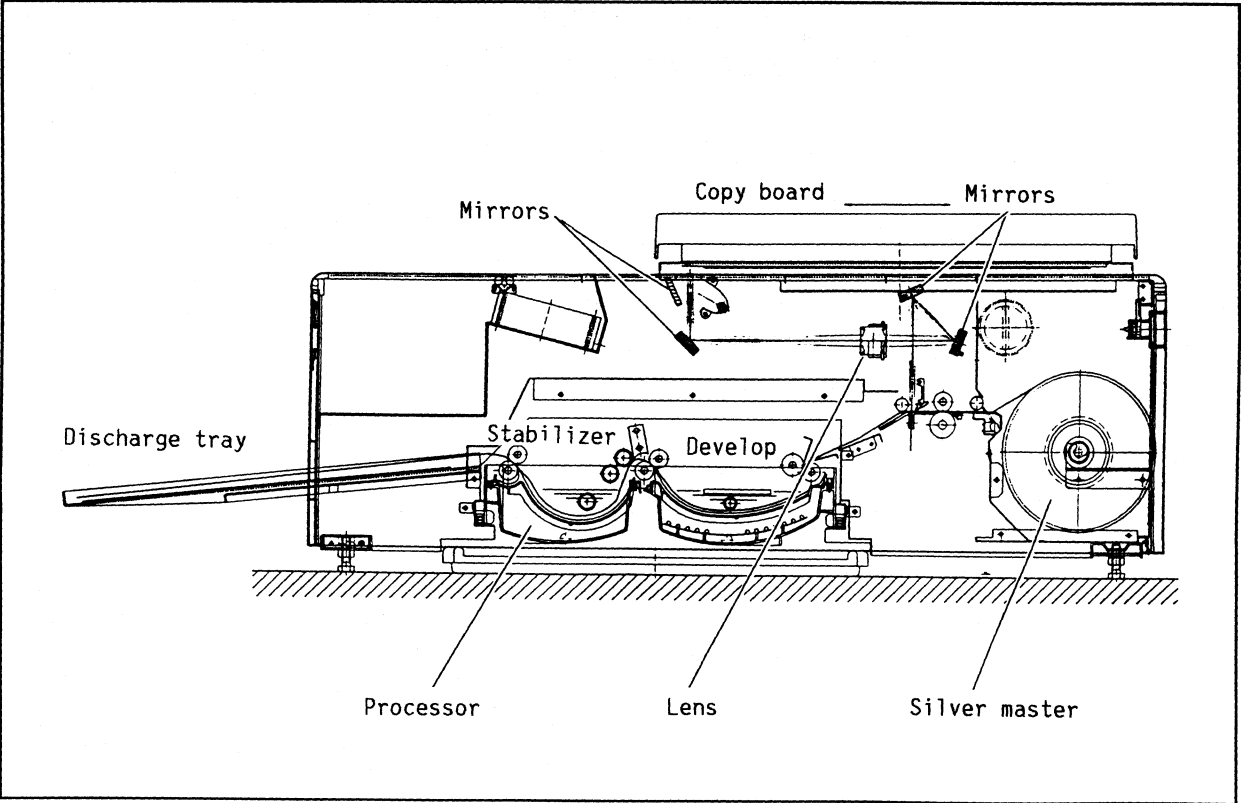

## 5. Installation Procedure

### ◆ Installation requirements

- ① Make sure the area where the machine is to be installed is well ventilated, with a temperature control to be between 50~86°F (10~30°C) and a humidity range of 40~70%.
- ② Avoid direct sunlight.
- ③ Install the machine on a stable, level base.
- ④ The required power supply is as follows: 1 $\phi$ 115V 1.2kW 10A.  
Use adequate wiring to handle the power requirements. The allowable voltage variation must be within  $\pm 10\%$  of the required voltage.  
\* A circuit breaker must be used. Also, the wiring should be installed by a qualified electrician.  
\* Be sure to connect the ground/earth, according to local safety requirements.
- ⑤ This machine is designed for table-top use; therefore, use a table of adequate size and strength (W 1000mm X D 600mm X H 600mm, weight: 70kg). Also, leave enough space around the table for servicing and maintenance as shown below.

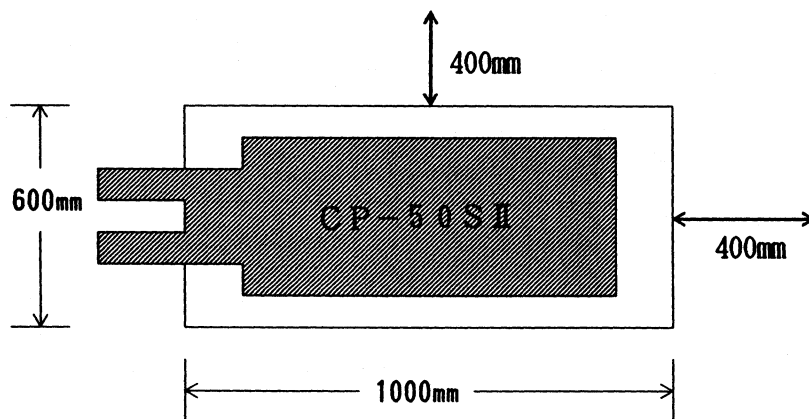

◆ Packing list

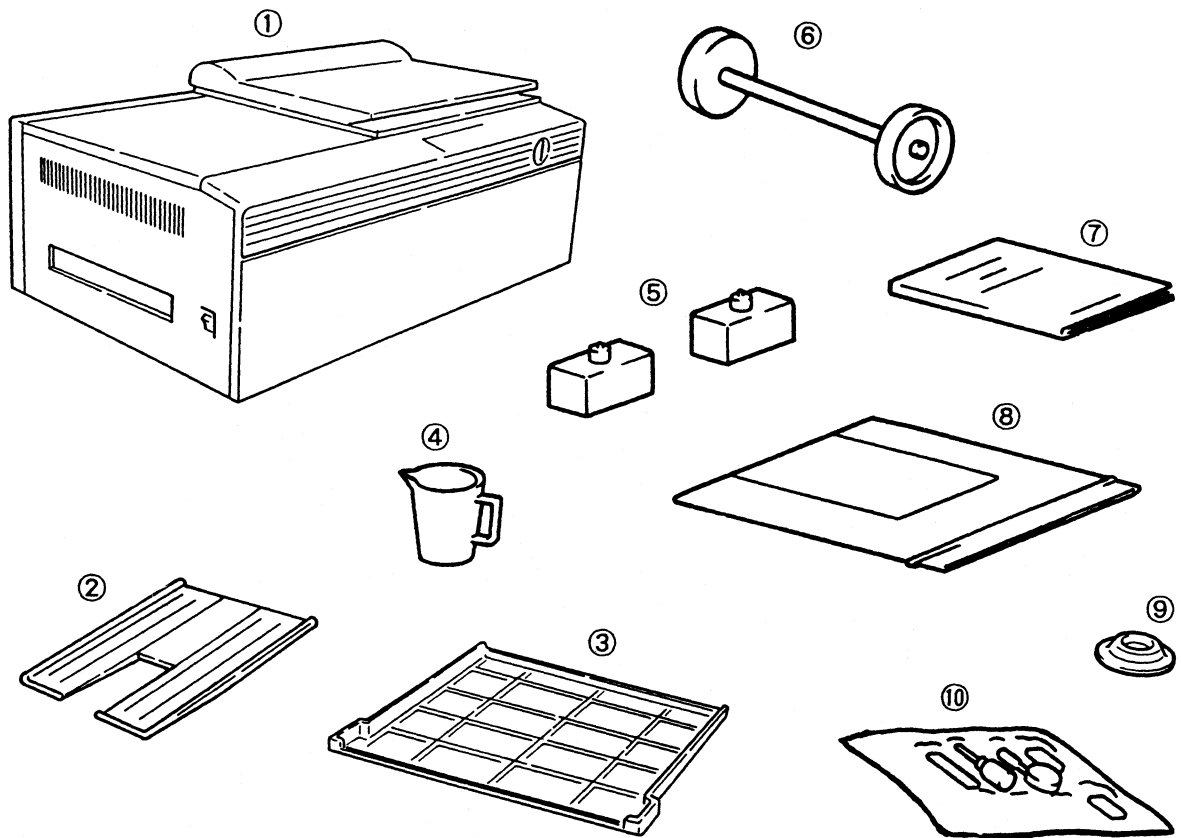

Packing list

No.	Name	Qty.
1	Main body	1
2	Discharge tray	1
3	Tray	1
4	Measuring cup	1
5	Replenisher tank	2
6	Spool ends (2), spool shaft	1 set
7	Operation manual and technical guide	1 set
8	Test chart and test sample	1 set
9	Base pad	4
* 10	Spare parts	1 set

\* Spare parts

Name	Qty.
Air brush	1
Cutter blade	1 set
Glass fuse 250V 0.5A	3
250V 3A	2
Ceramic fuse 250V 12A	1
Screws, bolts	1 set



◆ Main body installation

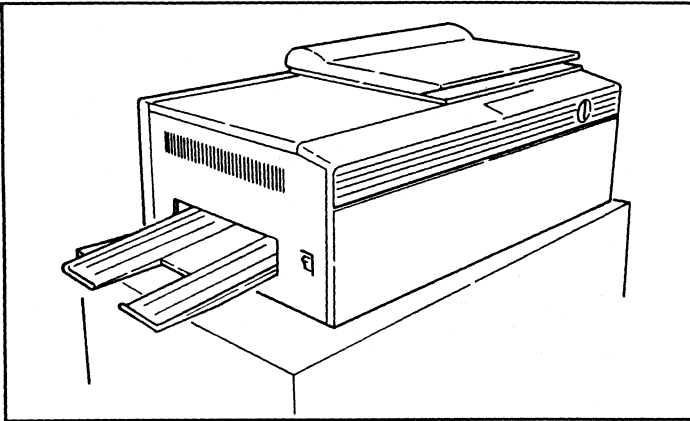

1. Place the main body on the table.

[NOTE]

The machine weighs approximately 70kg, therefore, two persons are needed to carry the machine. Hold the machine using the places

indicated by the  mark.

2. Install the discharge tray.

◆ Level check

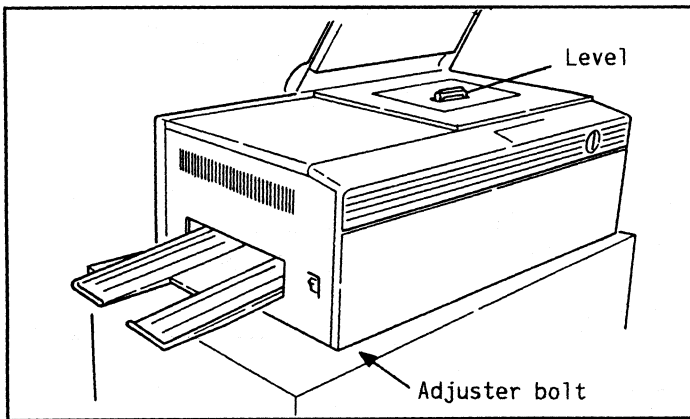

1. Place the base pads (4) under the adjuster bolts.
2. Place a level with a clean piece of paper underneath on top of the copy glass. Adjust the front/rear and left/right levels.

[NOTE]

Use the adjuster bolts to adjust the level of the machine.

### ◆ Cutter installation

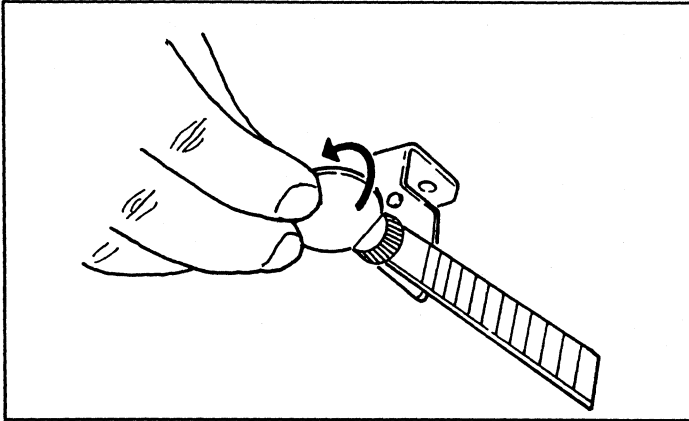

1. Remove the main body front cover and the cutter cover.
2. Attach the cutter blade to the cutter securing bracket.

#### [CAUTION]

Be very careful not to cut your hand when handling the sharp cutter blade.

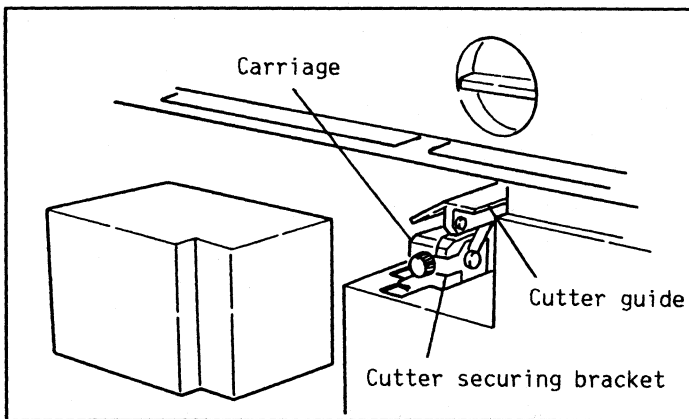

3. Insert the cutter blade into the cutter guide, then attach the cutter securing bracket to the carriage.

### ◆ Solution preparation

1. Place the tray under the processor unit.
2. Prepare the developer and fixer solutions separately, following the solution preparation section in the operation manual and then fill the respective processor tanks.
3. Fill the respective replenisher tanks and install them in the processor unit.

### ◆ Power connection

1. Check that the power switch is turned OFF.
2. Be sure to connect the power source to an adequate circuit breaker.

Required voltage: 1  $\phi$  115V

◆ Inspection and adjustment

- ① Turn ON the power switch, then install the master film roll in the master compartment following the operation manual instructions.
- ② Test the machine and perform exposures using the test chart, following the operation manual instructions.
- ③ Check the diagonal dimensions and adjust, if necessary. The machine is adjusted before shipping, but if the diagonal dimension deviation is too large, adjust following the procedure below.

<Procedure>

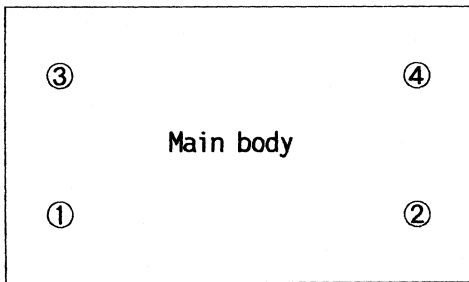
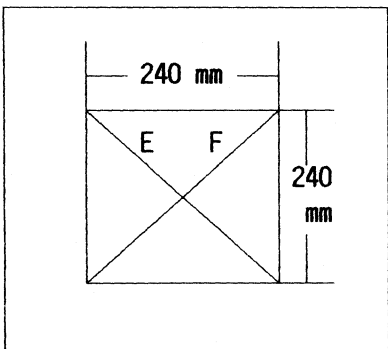

- 1) Place the test chart (or scaled paper) on the copy glass.
- 2) Expose the test chart, then measure "E" and "F".

Tolerance: less than 0.5mm

- If "E" > "F",
- lower ① of the main body, using the adjuster bolt, or raise ②.
- If "E" < "F",
- raise ① of the main body, using the adjuster bolt, or lower ②.
- \* If the adjuster bolt (M10) is turned 1 revolution, "E" and "F" are varied by approximately 1mm.

# Mechanical System

# 1. Optical System Check and Adjustment

The focus and magnification were carefully adjusted before shipment. However, if either appears out of adjustment, check and adjust following the procedure below.

## ◆ Check and adjustment

1. Distortion adjustment ——— Optical system mirror ① right/left movement
2. Focus adjustment ——— Optical system mirror ① right/left movement
3. Magnification adjustment — Lens right/left movement

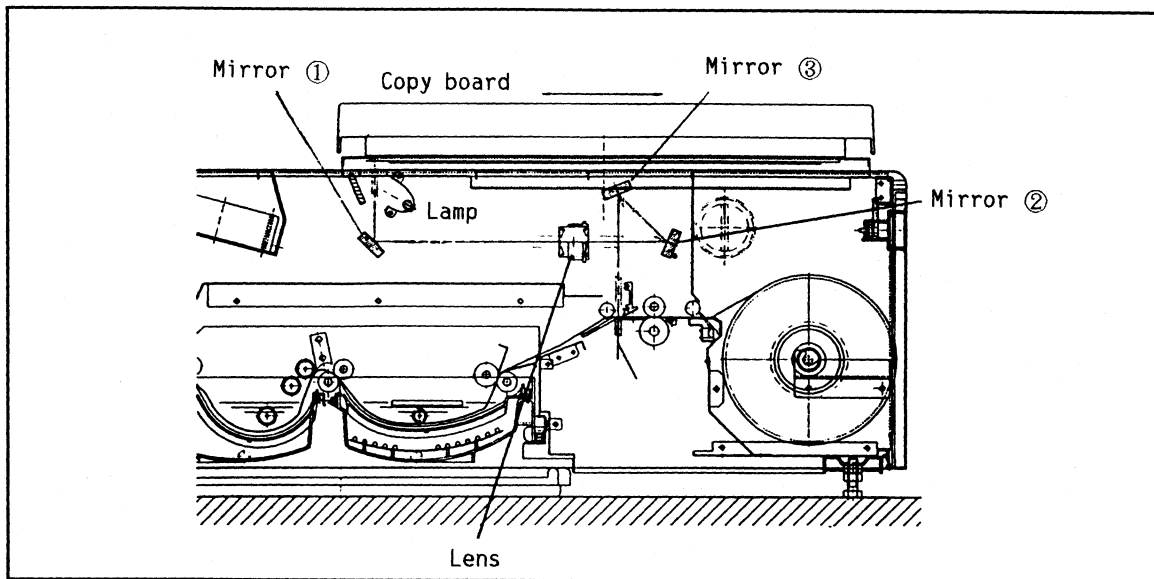

Distance between the original (C) and the lens (L) ———  $A = f \left(1 + \frac{1}{m}\right)$

Distance between the lens (L) and the exposure surface (P) —  $B = f (1 + m)$

f: lens focal length  
m: magnification

## 《Correct focus》

The theoretical relationship between the original, lens, and exposure surface is:

$$A = B \quad (\text{example } f: 150 \quad m: 1 \quad (100\%))$$

$$f \left(1 + \frac{1}{m}\right) = f (1 + m) \quad 150 \left(1 + \frac{1}{1}\right) = 150 (1 + 1)$$

$$\therefore A = B = 300$$

In actual use, different lenses have different focus values. Therefore, the value of "f" is not always 300. (unit: mm)

◆ Distortion/magnification check and adjustment

- Place the test chart or scaled paper (suitable for checking distortion and magnification) on the copy glass.
- Expose, with the master feed length set at about 470mm. Measure dimensions A, B, C, D and check the dimensional variation of a, b, c, d.

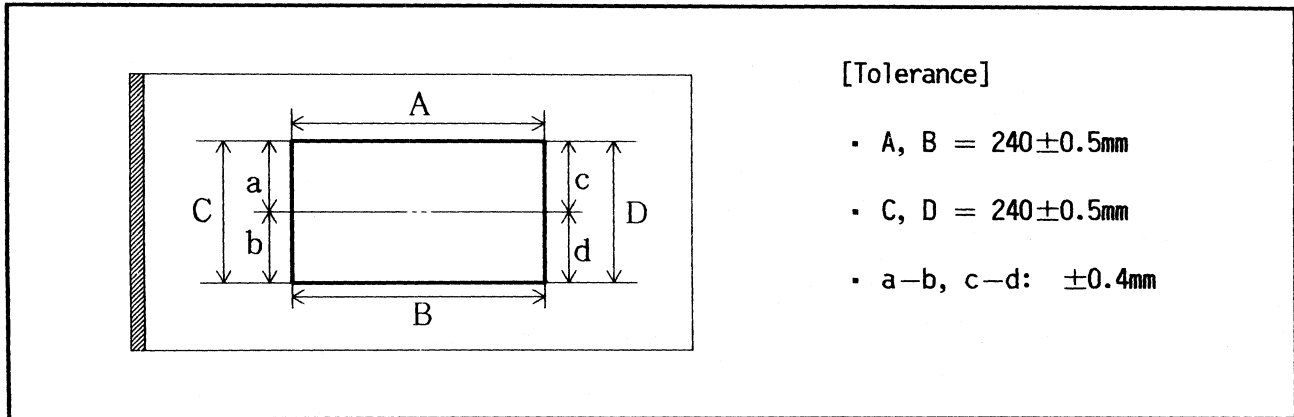

- \* The accuracy of A and B, in the feed length direction, is set by the machine and cannot be adjusted.
- \* The CP-50SII uses the slit-exposure method; therefore, measure C and D first, then measure a, b, c, d.

【Adjustment procedure】  $\Rightarrow$  Adjustment by moving Optical system mirror ① right/left.

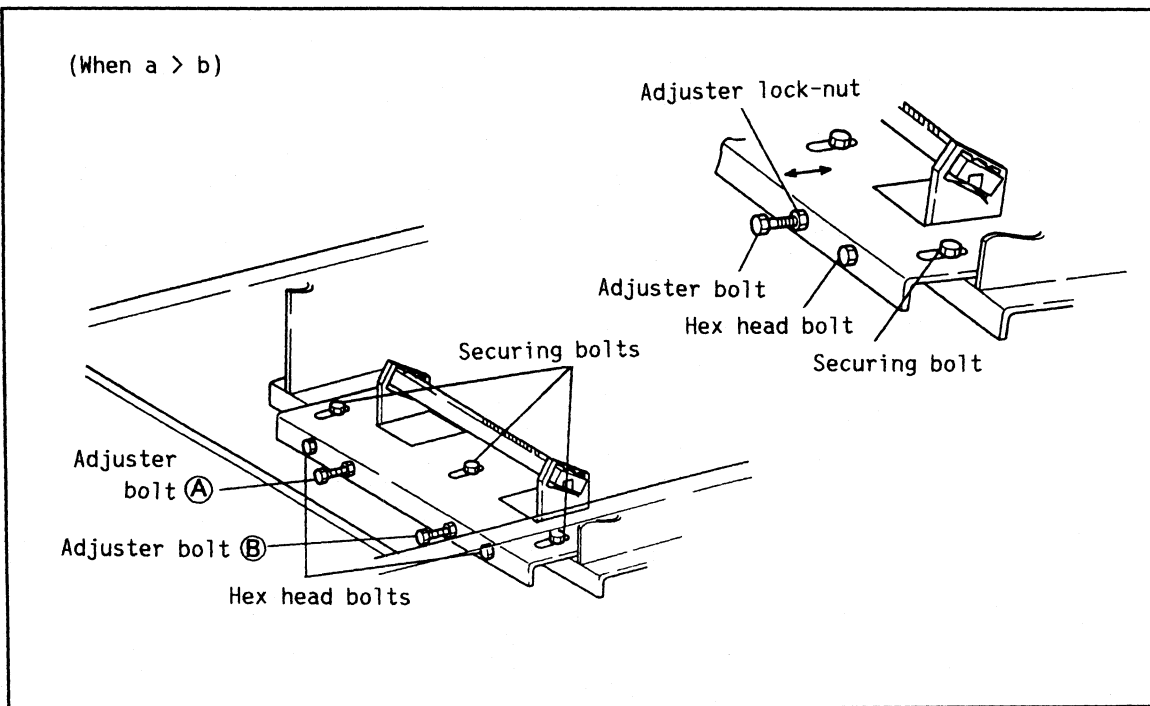

1. Loosen the securing bolts on the adjustment plate.
2. Loosen the hex head bolts (2).
3. Check which direction Optical system mirror ① should be moved (refer to the focus adjustment procedure).

4. To prevent the adjuster bolts from turning while holding them, loosen the adjuster lock nuts (right and left).
  5. If adjuster bolt ① is turned clockwise, adjuster bolt ② is turned counter-clockwise.
- \* Before adjusting the mirror, in order to repeat the correct positioning, be sure to make a mark on the adjuster bolts.

<Adjustment guideline>

The adjuster bolts will move about 0.3mm for each full turn.

6. Tighten the hex head bolts.
7. Tighten the securing bolts.
8. After checking the dimensions again, readjust if not correct.

#### ◆ Focus check

- Using the test chart (resolution chart) or a Mitsubishi reference chart, make an exposure while increasing the light intensity two-steps.
- The focus is correct if resolution of more than 10 lines/mm is obtained. If there is less than 10 lines/mm, adjust the focus.

【Adjustment procedure】 ⇒ Adjustment by moving Optical system mirror ① right/left.

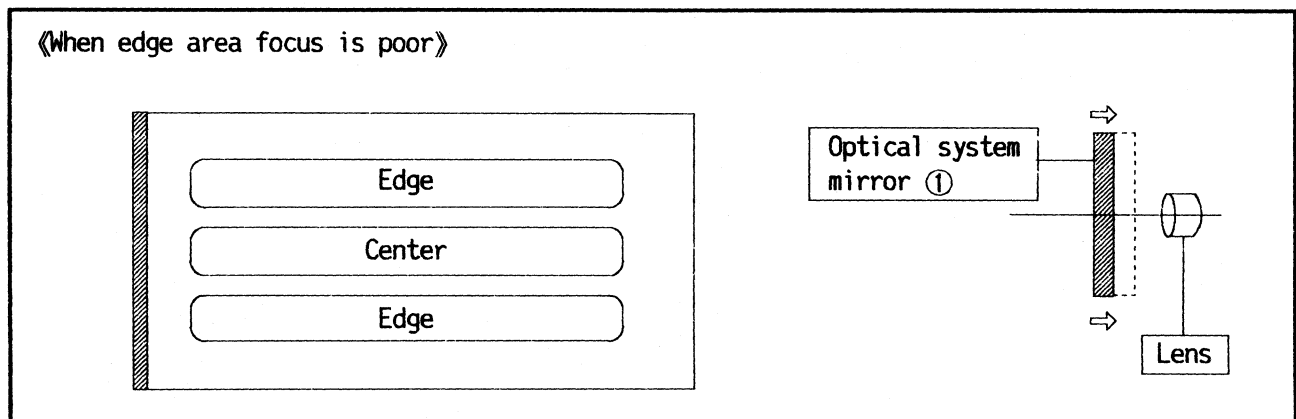

\* Before adjusting the mirror, in order to repeat the correct positioning, be sure to make a mark on the adjuster bolts.

1. Loosen the securing bolts on the adjustment plate.
  2. Loosen the hex head bolts (2).
  3. Turn the adjuster bolts counter-clockwise to move Optical system mirror ① towards the lens.
  4. While holding the adjuster bolts, to prevent turning, tighten the adjuster lock-nuts, then tighten the hex head bolts.
  5. Tighten the securing bolts, then make an exposure to check the focus.
- After checking the focus again, readjust if not correct.

◆ Magnification check

• Refer to Distortion/magnification check and adjustment (p.11).

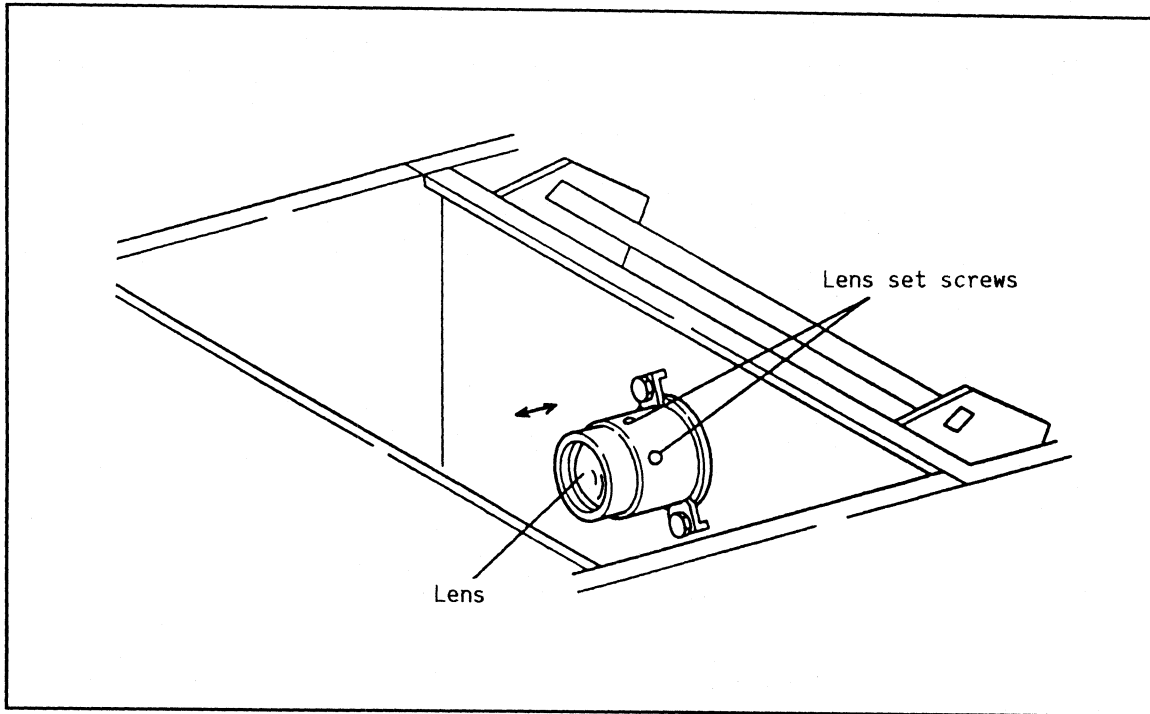

【Adjustment procedure】 ⇔ Adjustment by moving the lens right/left.

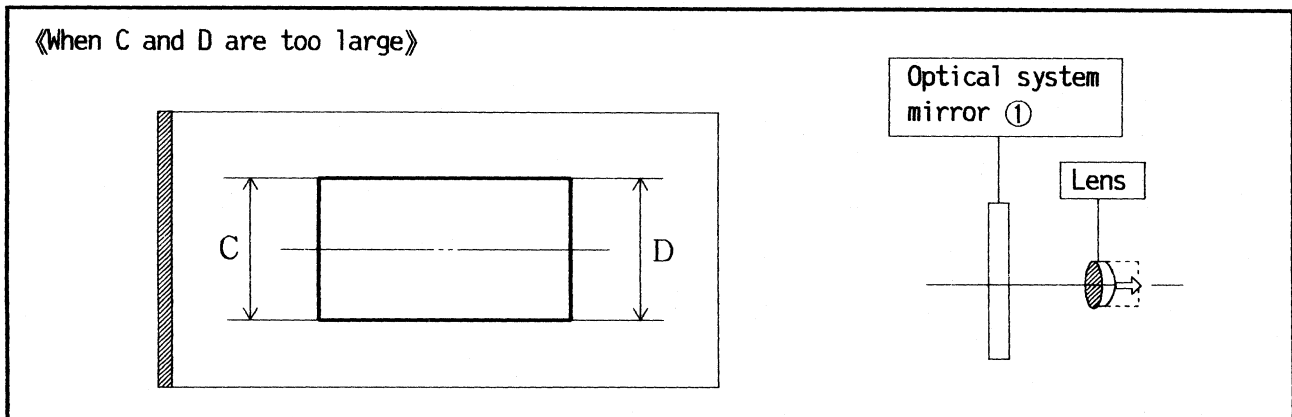

\* Before adjusting the lens, in order to repeat the correct positioning, be sure to make a mark on the lens body.

1. Loosen the lens set screws (two M3 hollow set screws).
2. Push the lens towards mirror ②, then tighten the set screws.
3. Make an exposure, then check dimensions C and D.

— [Adjustment guideline] —

When lens adjustment equipment is used, the exposure dimension will change by about 1.5mm for each full turn.



## 2. Mirror Replacement

Scratches on the mirrors may affect the image quality. Replace if scratched.

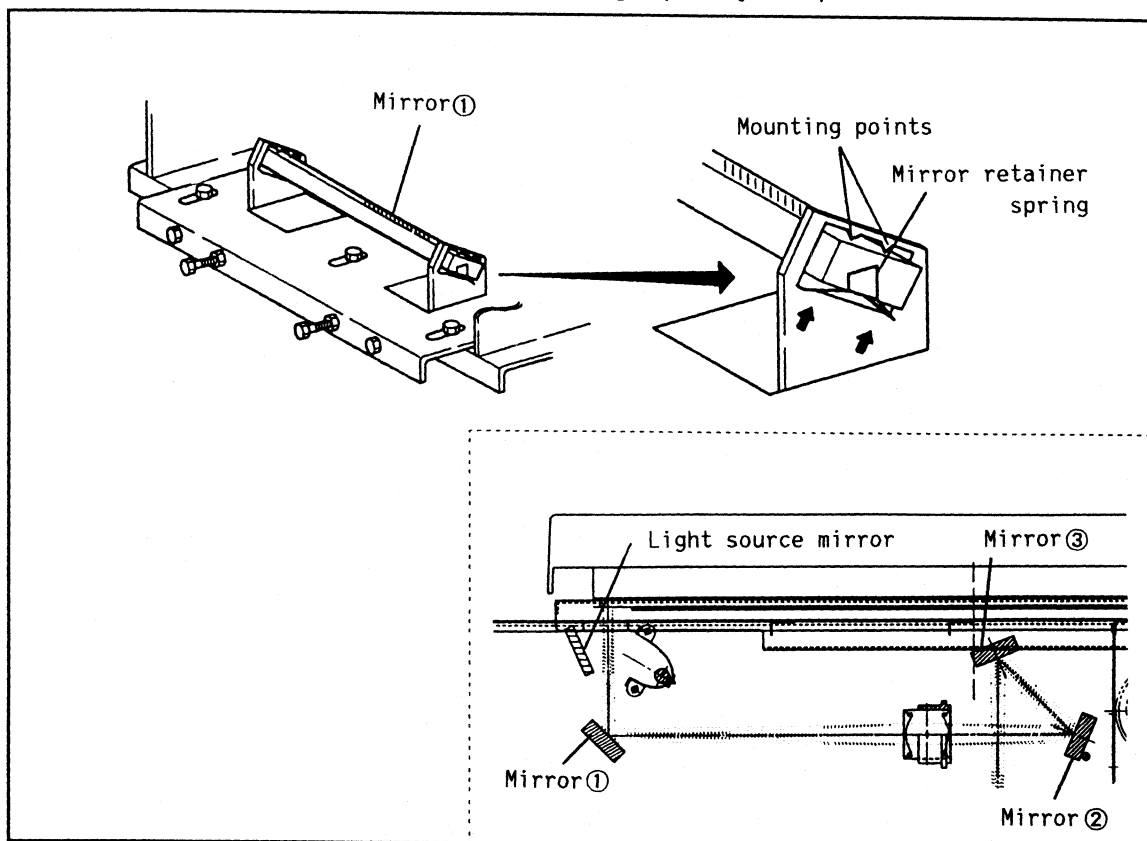

\* The Optical system mirror brackets have three mounting points to prevent the mirrors from twisting (two points on the reflection side and one on the opposite side).

### 【Removal】

1. Turn OFF the power switch.
2. Remove the upper-left main body cover.
3. While pushing the mirror retainer spring in the direction of the arrows, slide the spring to the outside and remove.
4. Remove the mirror.

\* The light source mirror has its retainer spring on the reflection side.

### 【Installation】

1. Install the new mirror.

#### 【Caution】

- \* Wear clean gloves or use a clean cloth to avoid scratching the surface.
- \* Make sure the retainer spring is secured properly.

2. To reassemble, follow the removal procedure in reverse.
3. Make an exposure, then check the focus and magnification.

### 3. Thermal Fuse Replacement

Light source unit fuse

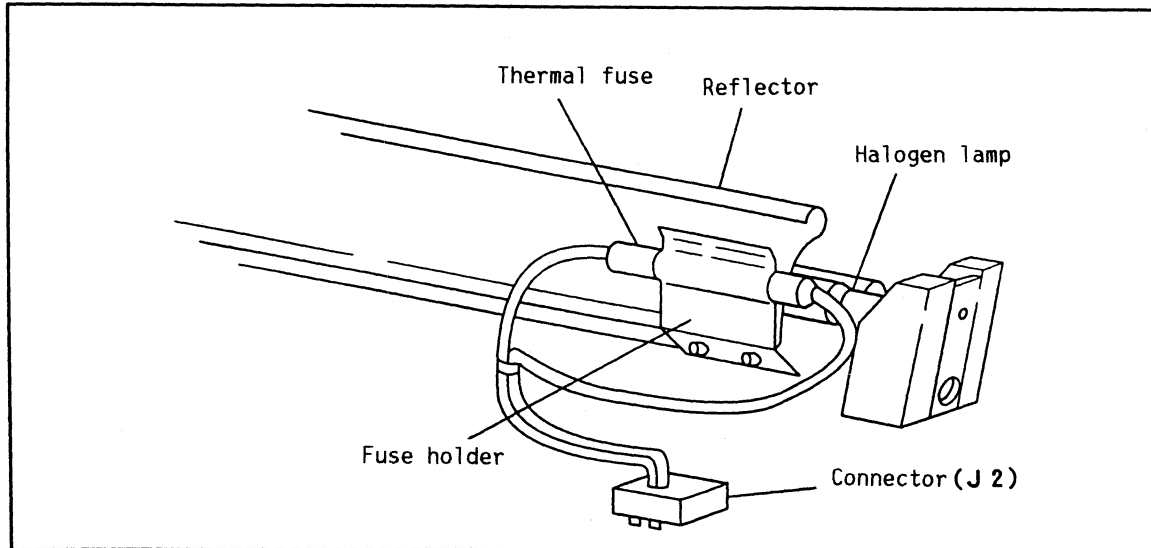

#### 【Removal】

1. Turn the nip roller knob to the free position (○). Press start button.
2. After the copy board reaches the left side, turn OFF the power switch.
3. Remove the upper-right main body cover.
4. Disconnect the thermal fuse connector (J2).
5. Remove the thermal fuse from the fuse holder.

#### 【Installation】

1. Install the new thermal fuse.
2. To reassemble follow the removal procedure in reverse.
3. Turn ON the power switch to move the copy board to the right.

# 4. Drive Belt Replacement

## Rear-side drive belt replacement

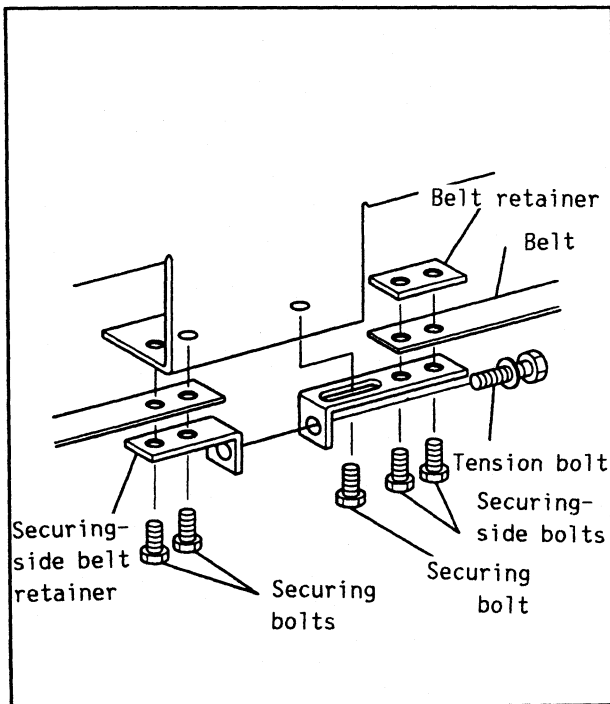
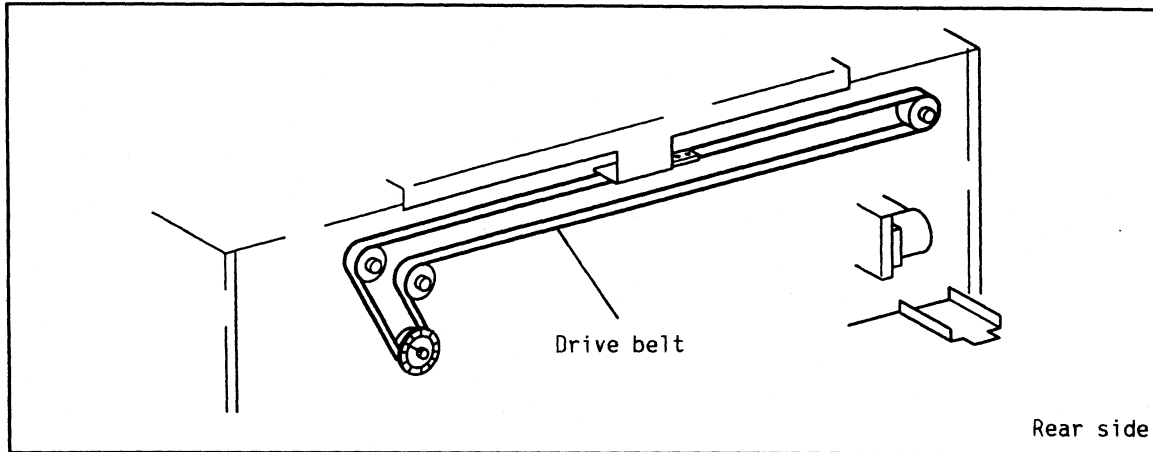

### 【Removal】

1. Turn the nip roller knob to the free position (○). Press start button.
2. After the copy board reaches the left side turn OFF the power switch.
3. Remove the rear main body cover.
4. Remove the belt tensioner securing bolt and tension bolt.
5. Remove the securing-side belt retainer and securing bolts from the securing-side.
6. Remove the drive belt from the pulleys.

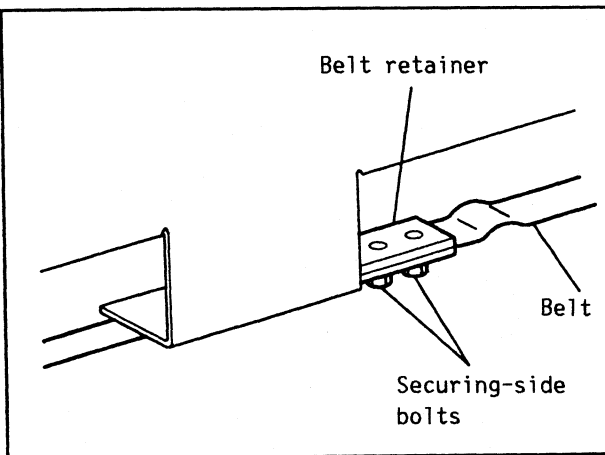

### 【Installation】

1. To install the new drive belt, follow the removal procedure in reverse.
- \* During installation, keep the copy board at the discharge-side.
  - \* Make sure the drive belt edges are parallel to the belt retainer, belt tensioner, and securing-side belt retainer.
  - \* Temporarily tighten the tension bolt.

2. Turn ON the power switch to move the copy board to the right.

\* Tighten the tension bolt until the copy board just begins to move. After that point, turn the tension bolt 1.5 more revolutions.

## 5. Copy Board Contact Pad Replacement

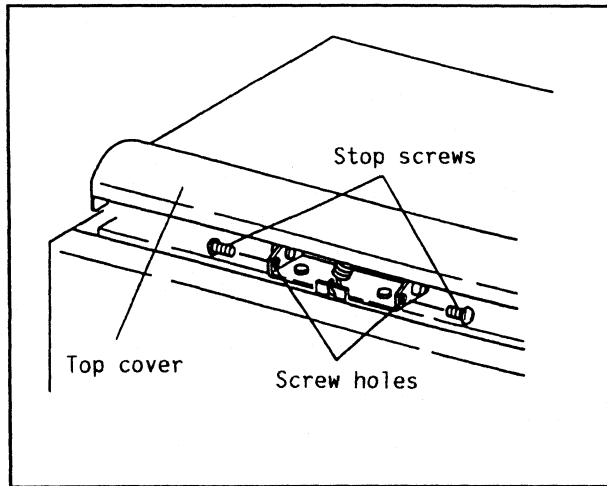

### 【Removal】

1. Turn OFF the power switch.
2. Insert the stop screws into the screw holes from the rear of the machine and tighten.

- \* Use M4 screws (20 mm) as stop screws.
- \* Do NOT tighten the stop screws fully.

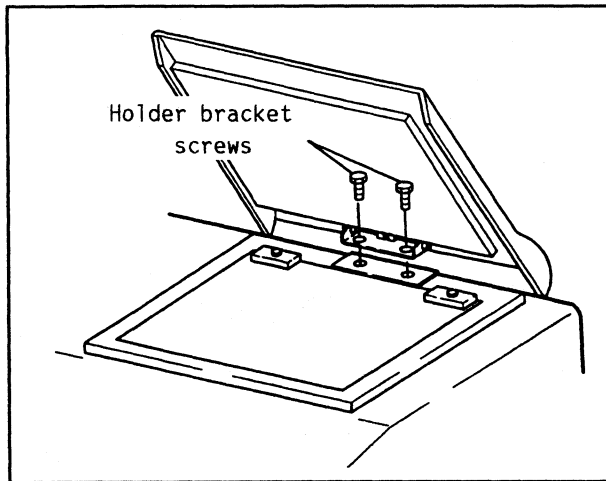

3. Open the top cover, remove the holder bracket screws, then remove the top cover from the main body.
4. Remove the contact pad securing screws and the contact pad.

- \* Some screws have washers; note the quantity and position.

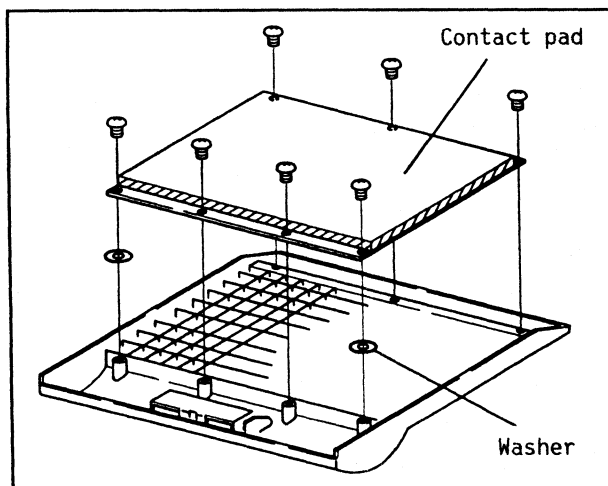

### 【Installation】

1. Attach the new contact pad to the top cover.

- \* Use the same positions and the same quantity of washers. (Use the washers for adjusting the contact pressure.)

2. To reassemble, follow the removal procedure in reverse.

- \* When installing the top cover, make sure it is aligned with the copy glass and that there are no gaps between the glass and the contact pad.

## 6. Original Positioning Sheet Replacement

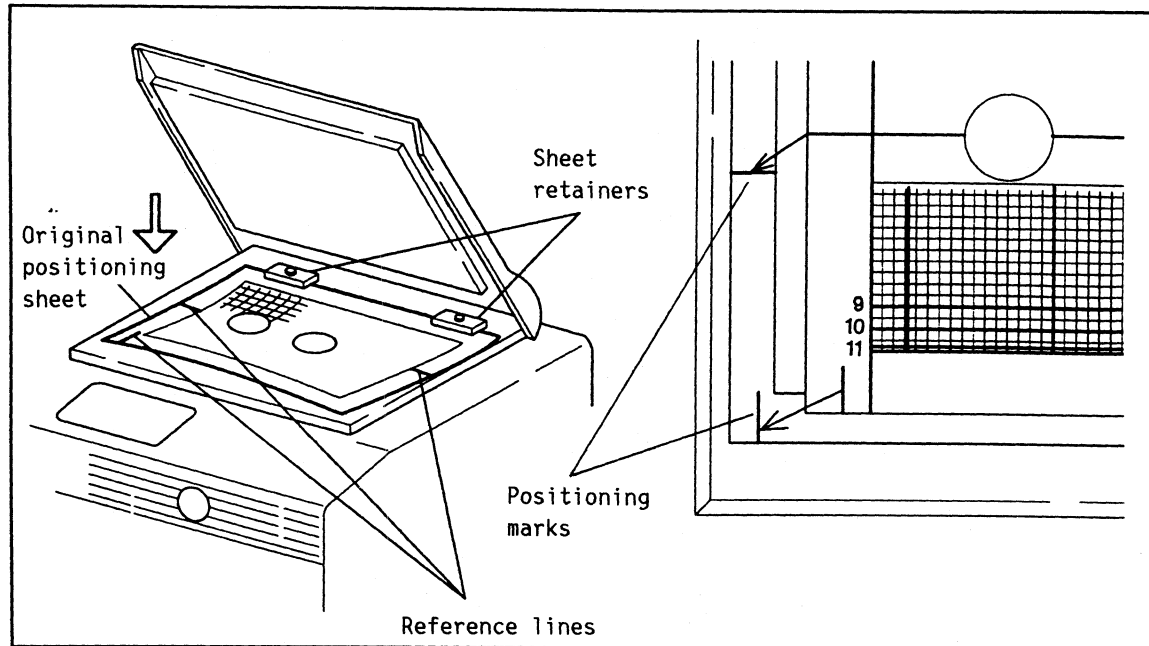

### **【Removal】**

1. Turn OFF the power switch.
2. Open the top cover, loosen the sheet retainer screws, then remove the original positioning sheet.

### **【Installation】**

1. Place the new original positioning sheet on the copy glass and align using the positioning marks (3).
2. Secure the sheet using the sheet retainer screws.

## 7. Copy Glass Replacement

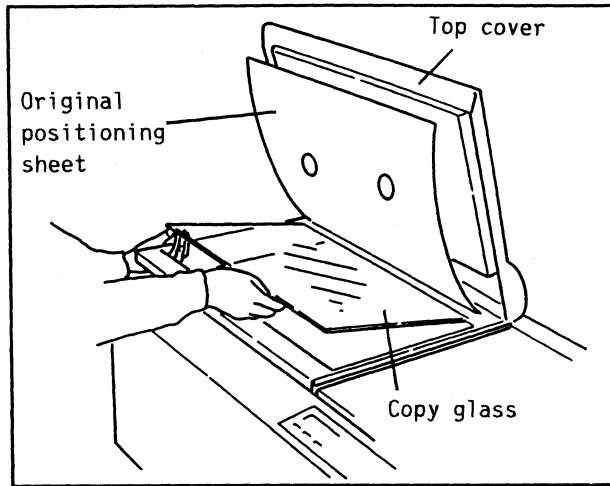

### 【Removal】

1. Turn ON the power switch.
2. Turn the nip roller knob to the free position (○). Press start button.
3. After the copy board reaches the left side, turn OFF the power switch.
4. Raise the top cover and original positioning sheet, then remove the copy glass.

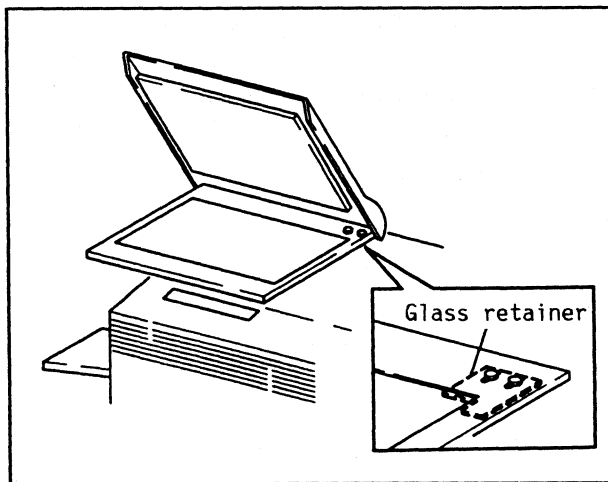

### 【Installation】

1. Install the new copy glass.
  - \* If the glass is difficult to install, loosen the glass-retainer screws, then adjust the retainer and tighten.
2. Turn ON the power to move the copy board to the right.

## 8. Halogen Lamp Replacement

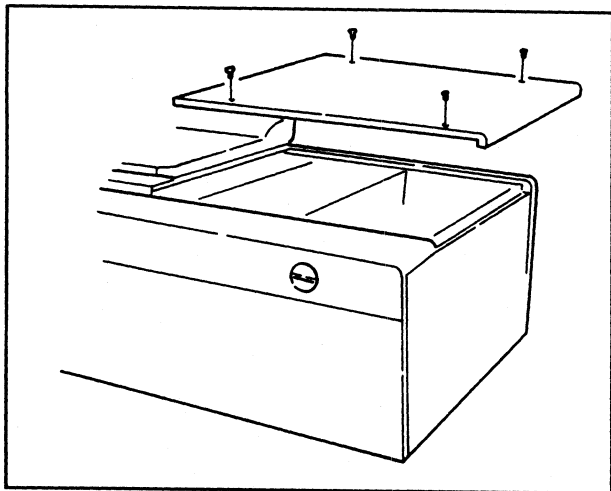

### 【Removal】

1. Turn the nip roller knob to the free position (○). Press start button.
2. After the copy board reaches the left side, turn OFF the power switch.
3. Remove the right upper cover from the main body.
4. Loosen the reflector securing screws.
5. Remove the halogen lamp.

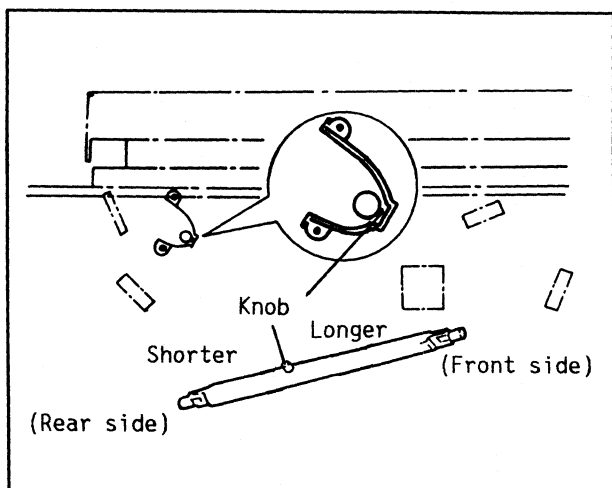
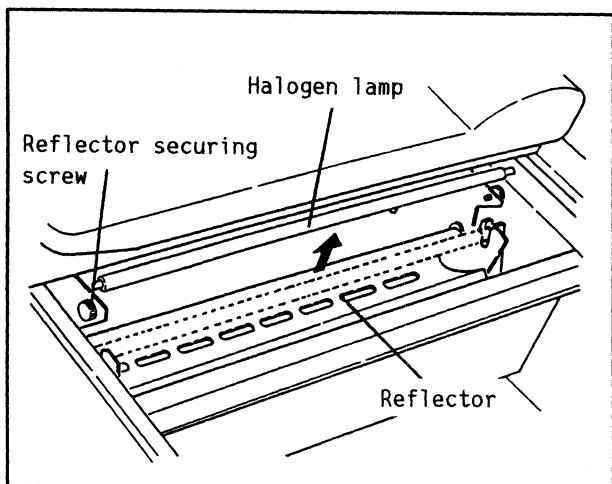

### 【Installation】

1. Install the new halogen lamp.

### 【Caution】

- Do not touch lamp with bare hands. Wear clean gloves or use a clean, dry cloth while handling the lamp. Oil from fingerprints may shorten the life of the lamp and/or affect product quality.
- If the lamp gets dirty, wipe with common lens cleaning paper with a little alcohol.
- When installing the lamp, make sure the knob faces the reflector.

2. After installing the lamp, check that the thermal fuse is mounted at the specified position on the reflector.
3. Replace the right upper cover.
4. Turn ON the power switch to move copy board to the right.



# 9. Lubrication

For lubrication use Dow Corning "Moly Kote PG-641".

## <Processor drive gear>

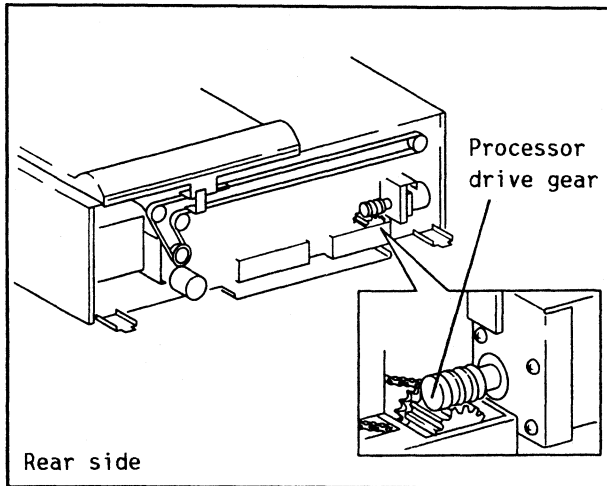

1. Turn OFF the power switch.
2. Remove the main body rear cover.
3. Apply the grease to the processor drive gear.

## <Cutter mounting bracket>

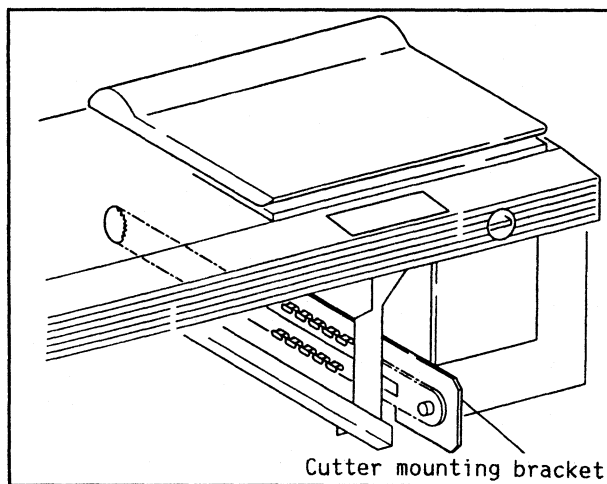

1. Turn OFF the power switch.
2. Remove the main body front cover.
3. Disconnect the processor tank connector tube.
4. Drain the solutions from the processor into a waste container.
5. Draw out the processor.
6. Remove the processor rail.
7. Remove the cutter cover and apply the grease to the cutter mounting bracket.

## <Cutter drive gear>

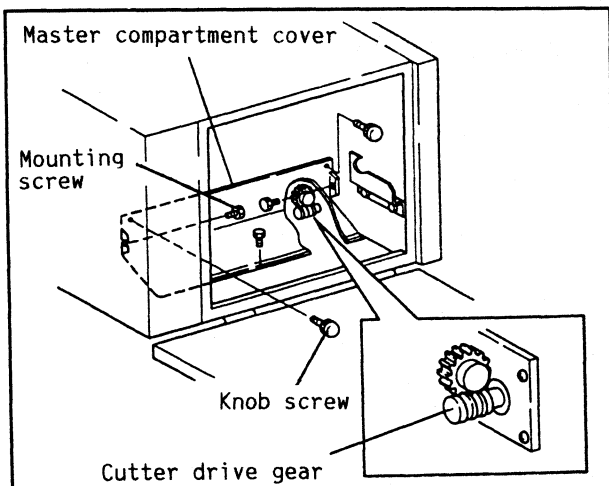

1. Turn OFF the power switch.
2. Open the main body silver master cover.
3. Remove the mounting screws (3) and knob screws (2) from the master compartment cover, then remove the master compartment cover.
4. Apply the grease to the cutter drive gear.

# 10. Copy Glass Cleaning

## <Upper face cleaning>

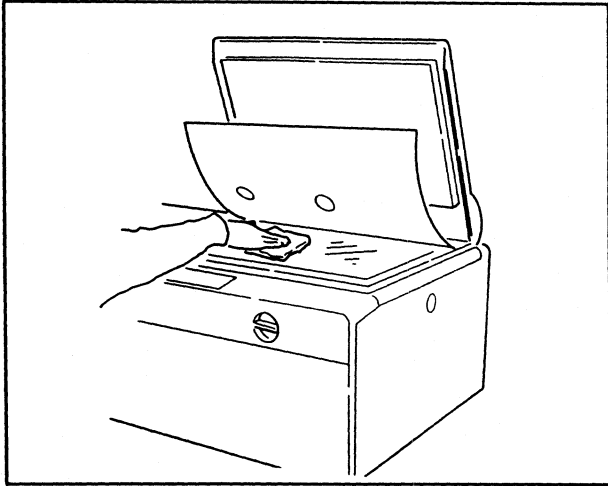

1. Open the copy frame and clean the upper face of the copy glass.

### [Caution]

Use a common glass cleaner and wipe with a soft cloth. Be careful not to leave behind any traces of the cleaning solution.

## <lower face cleaning>

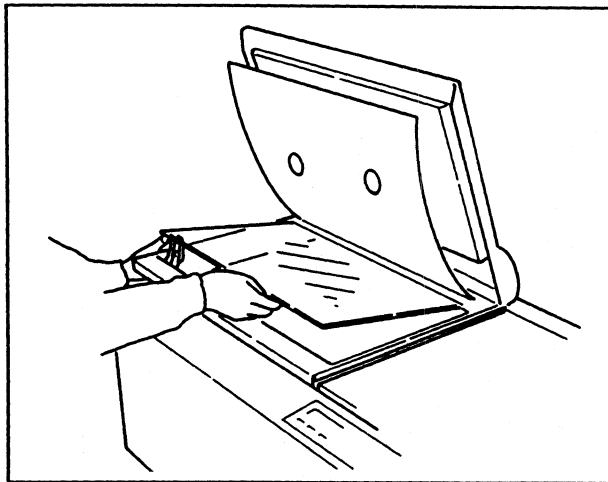

1. Turn the nip roller knob to the free position (○). Press start button.
2. After the copy board reaches the left side, turn OFF the power switch.
3. Open the copy frame and remove the copy glass and clean.

### [Caution]

Use caution while handling the copy glass.

4. After cleaning, replace the copy glass into the glass frame and secure.

\* If the glass is difficult to install, loosen the glass retainer screws, then adjust the retainer and tighten (refer to p.20)