

MITSUBISHI GRAPHIC ARTS SYSTEM

CP-414V

NOTE

This equipment has been tested and found to comply with the limits for a Class A digital device, pursuant to Part 15 of the FCC Rules. These limits are designed to provide reasonable protection against harmful interference when the equipment is operated in a commercial environment. This equipment generates, uses, and can radiate radio frequency energy and, if not installed and used in accordance with the instruction manual, may cause harmful interference to radio communications. Operation of this equipment in a residential area is likely to cause harmful interference in which case the user will be required to correct the interference at his own expense.

* * * * *
*
* **Be sure to read this page!** *
*
* * * * *

In order to use the machine correctly and safely, it is vital that you read the following points carefully.

Points to note :

- (1) Make sure you have read and thoroughly understood all instruction manuals, etc. before you begin to use the machine.
If there is any item which you do not understand, please consult one of our agents or distributors.
- (2) Connect the machine to a power source which has an earth leakage breaker attached. The output rating is written on the nameplate. The working current should be 30mA. Electric connections should be handled by a qualified electrician.
- (3) The earth wire of the power cable (green/yellow-spiral line) should be grounded. The earth wire must be connected by a qualified electrician.
- (4) Chemicals may harm skin or eyes, so always read the instructions on the box label before use.
- (5) If you have to remove any of the covers for any reason, always switch off the machine itself and also switch off at the mains on the wall. This is to avoid the danger of electric shock due to electricity flowing into any of the electrical parts inside the machine.
- (6) Fires are often caused by changing the fuse, so always make sure to replace the fuse with one of the same rating.
- (7) Do not look directly into the lamp while it is lit. If you experience any eye irritation, consult a doctor.
- (8) Points to note when changing the lamp
 - (a) Switch off the machine
 - (b) Switch off at the mains on the wall
 - (c) Replace with the same type of lamp as the one currently in use, and check the voltage inscription.
 - (d) Wait at least five minutes for the lamp to cool down before attempting to replace it.
- (9) The machine uses motors which include a thermal overload protection relay inside. This type of motor restarts automatically so, during maintenance, always switch off the machine itself and also switch off at the mains on the wall.
- (10) Always consult a service engineer or our distributor before attempting to extend the electric cable.
- (11) If there is any sign that the covering on the electric cable has broken, stop the machine immediately and contact a service engineer to come and repair it.
- (12) When wiring the machine, make sure that the cable does not dangle over the edge of the table or counter since damage could be caused to the covering, and there is also the danger of a short circuit or of somebody touching the cable directly.
- (13) Do not stand on the electric cable or pull it forcefully.
- (14) Be particularly careful in operating the machine when children are in the vicinity. Do not leave the machine unattended while it is in operation.

CONTENTS

- 1. INTRODUCTION**
- 2. SPECIFICATIONS**
- 3. GENERAL DRAWINGS**
- 4. PROCESS CHART**
- 5. PRECAUTIONS IN HANDLING**
- 6. CONDITIONS FOR INSTALLATION**
- 7. MACHINE DESCRIPTION**
 - 7.1 General Structure
 - 7.2 Descriptions of the Components
 - 7.2.1 Power switch
 - 7.2.2 Control panel
 - 7.3 Copy Holder
 - 7.3.1 Loading the copy
 - 7.3.2 Positioning the copy
 - 7.4 Lens-Mirror Assembly
 - 7.5 Photographing Section
 - 7.5.1 Loading a material roll
 - 7.5.2 "EMPTY" message
 - 7.5.3 Material splice detection
 - 7.6 Processor
 - 7.6.1 Preparation of processing solutions
 - 7.6.2 Developing tank
 - 7.6.3 Stabilizing tank
 - 7.6.4 Replenishment
 - 7.6.5 Replacement of the processing solutions
 - 7.6.6 Control of processing liquid level
- 8. PHOTOGRAPHING**
 - 8.1 Photographing Procedure
 - 8.2 How to Determine Standard Exposure
 - 8.3 How to Determine the Optimum Exposure Level
- 9. MAINTENANCE**
 - 9.1 Maintenance Mode
 - 9.2 Routine Maintenance
 - 9.2.1 Processor
 - 9.2.2 Replacement of the cutter blade
 - 9.2.3 Replacement of the halogen lamp
 - 9.2.4 Care of the copy glass
 - 9.2.5 Lens-mirror assembly
 - 9.2.6 Cleaning the dryer inlet rollers
 - 9.3 Lubrication
 - 9.4 Order of Parts

10. TROUBLESHOOTING

10.1 Error Messages

11. AUTOMATIC REPLENISHMENT DEVICE

11.1 Components

11.2 Control Panel

11.3 Operating the Replenishment Device, and Changing Replenishment Time

11.3.1 Automatic replenishment mode

11.3.2 Initial replenishment mode

11.4 Control of Activator Level

1. INTRODUCTION

We at Mitsubishi are delighted that you have selected the Silver Master Platemaker CP-414V. The CP-414V uses a microprocessor-based system for automatic focusing, exposure control and exposing position selection, covering up to A3 size with a size variation capability ranging from 50% to 105%.

This operation manual provides the information necessary to ensure the continued satisfactory operation of the machine. Please read the manual prior to usage.

For information on printing methods, please refer to our booklet, "Silver Master Technical Guide."

2. SPECIFICATIONS

Material roll/loading :	SLM-R11 or SLM-F / loading two rolls in the magazine
Roll width (cm) :	22.9 (9"), 25.4 (10"), 27.9 (11"), 30.5 (12"), 31.0 (12-1/5"), 32.4 (12-3/4"), 37.0 (14-9/16"), 40.4 (15-7/8"), 41.4 (16-3/10")
Material cut length (cm) :	22.5-58.0 (in 1mm increments /8.85"-22.83")
Effective exposure area (cm) :	40.4×53.4 (82.2%-105%) /15-7/8"×21.02" 36.1×46.6 (70.7%) /14.21"×18.11" 25.4×33.0 (50%) /10"×12.79" (ineffective area: leading end 2.3 ; trailing end 0.3)
Max. exposure area (cm) :	41.4×58.0 (50-105%/16 5/16"×22 53/64")
Max. copy size (cm) :	40.4×53.4 (100% /15 7-8"×21.0") 50.5×66.0 (80.8% /19 7/8"×25 9/16") 50.8×66.0 (80.8-50% /20.0"×25 9/16")
Max. copy carrier sheet size (cm) :	59.5×73.0 /23 1/2"×28 3/4"
Lens :	f=210mm (fixed diaphragm)
Magnification :	50-105% (auto-focus)
Exposure method :	Slit exposure with copy and material moving
Copy mounting method :	Copy image face down; 180mm/7.09" pin bar and an auto-centering function provided
Multiple exposure :	Automatic double exposure, multiple exposure
Cutter :	Cutting by sliding
Exposure control :	Digital illuminance control, Magnification follow-up illuminance control
Light source :	One halogen lamp 1250W
Control panel :	Flat panel for interactive operation
Material splice detection :	Display, alarm buzzer, automatic cut beyond preset length
Dehumidifier :	Heater
Processor tank capacity :	Activator 7 ℓ /1.85USgal, stabilizer 6 ℓ /1.59USgal
Replenisher container capacity :	Liquid level control type: Activator 1 ℓ /0.26USgal, stabilizer 1 ℓ /0.26USgal Automatic replenishment type : Activator 10 ℓ /2.6USgal stabilizer 10 ℓ /2.6USgal
Initial platemaking time :	1min.58sec. per plate (plate length 45.0cm/17.72")/60Hz
Cyclic platemaking time :	42sec. per plate (plate length 45.0cm/17.72")/60Hz
Copy moving speed :	19-40 mm/sec /0.75"-1.57"
Processor speed :	12.0mm/sec/60Hz / 0.47inch/sec/60Hz

Activator temperature control :	350W panel heater with thermostat ($29 \pm 3^{\circ}\text{C}/84.2 \pm 3^{\circ}\text{F}$); heater off during exposure
Dryer :	400W fin heater, high/low switching with thermo-control
Safety measures :	in compliance with the relevant safety standards
Electricity :	200V, 2.5kW, 14A, single-phase
Machine dimensions :	115.5(W) X 79.5(D) X 110.0(H) cm /45 9/32" X 31 10/32" X 43 3/4"
Weight :	230kg /507lb (no chemicals included)

3. GENERAL DRAWINGS

GENERAL DRAWINGS

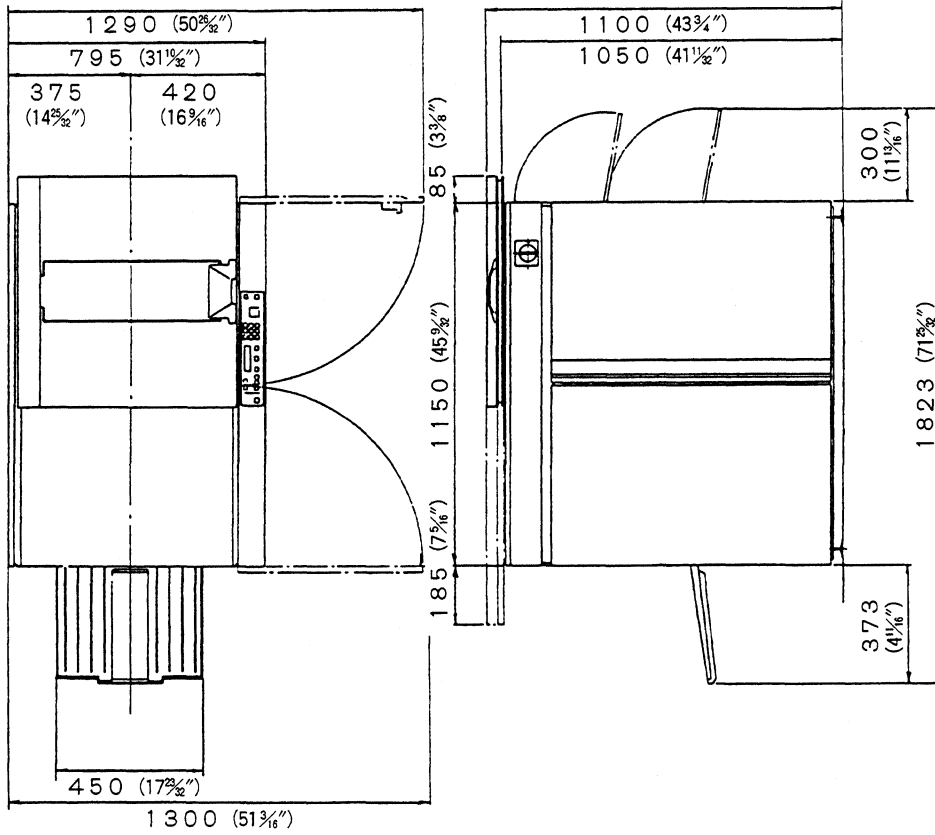
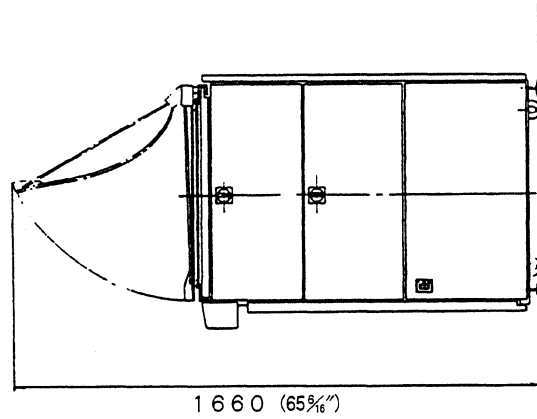

4. PROCESS CHART

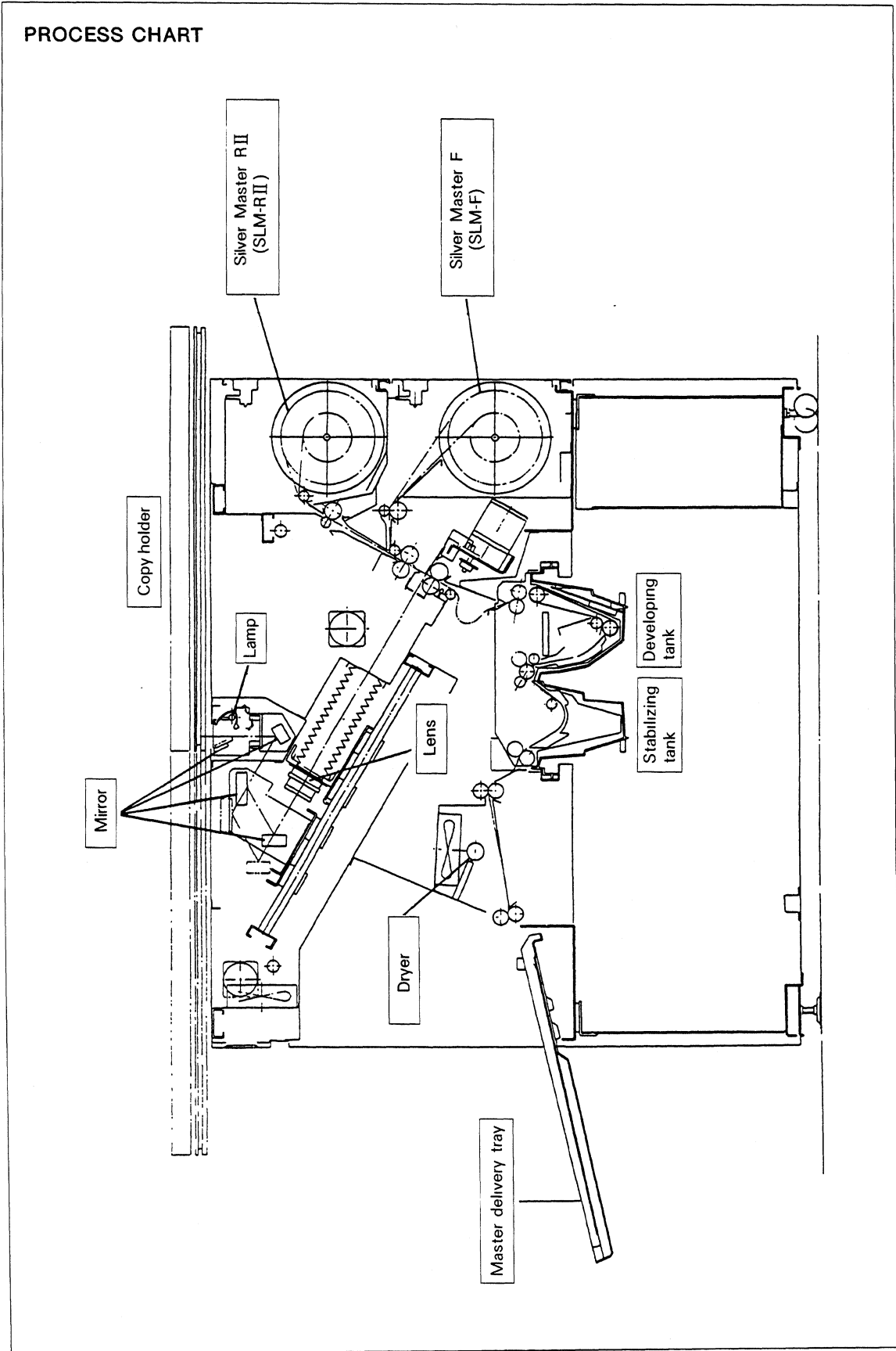

5. PRECAUTION IN HANDLING

Be extremely careful with the copy holder!

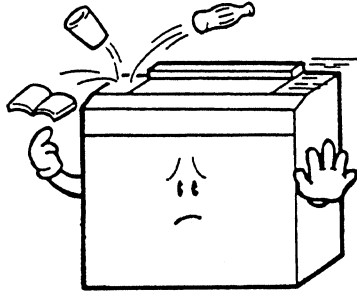

Don't put anything on the copy holder. Upon pressing the start Key the holder moves to the left.

Don't touch!

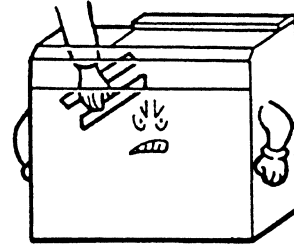

Never touch the lens mirror while cleaning as careless fingering may cause deterioration.

6. CONDITIONS FOR INSTALLATION

No vibration

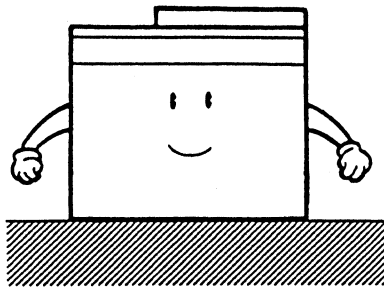

Choose a vibration-free place with an even, level floor surface. The machine (with no chemicals) weight 230kg /507lb.

**Power supply: 200V 2.5kW(14A)
single-phase**

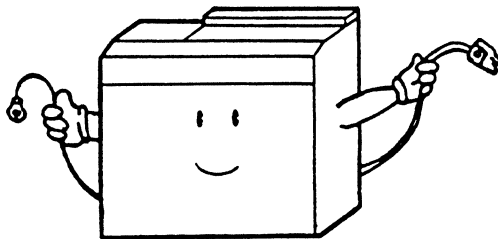

Use an exclusive power line.

Never fail to ground the machine in accordance with the relevant regulations.

Normal temperature and humidity

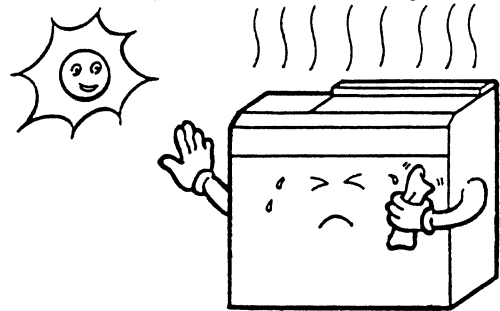

The room temperature should be between 10 to 30°C (50 to 86°F) and the humidity between 40 to 70%. Avoid direct sunlight.

Service area (cm)

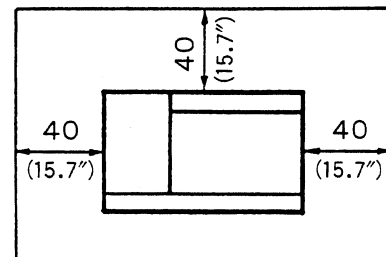

Be sure to keep a clear space around the machine for inspection. Machine dimensions: 115(W) × 79.5(D) × 110(H)cm
45 9/32(W) × 31 10/32(D) × 43 3/4(H)inch

7. MACHINE DESCRIPTION

7.1 General Structure

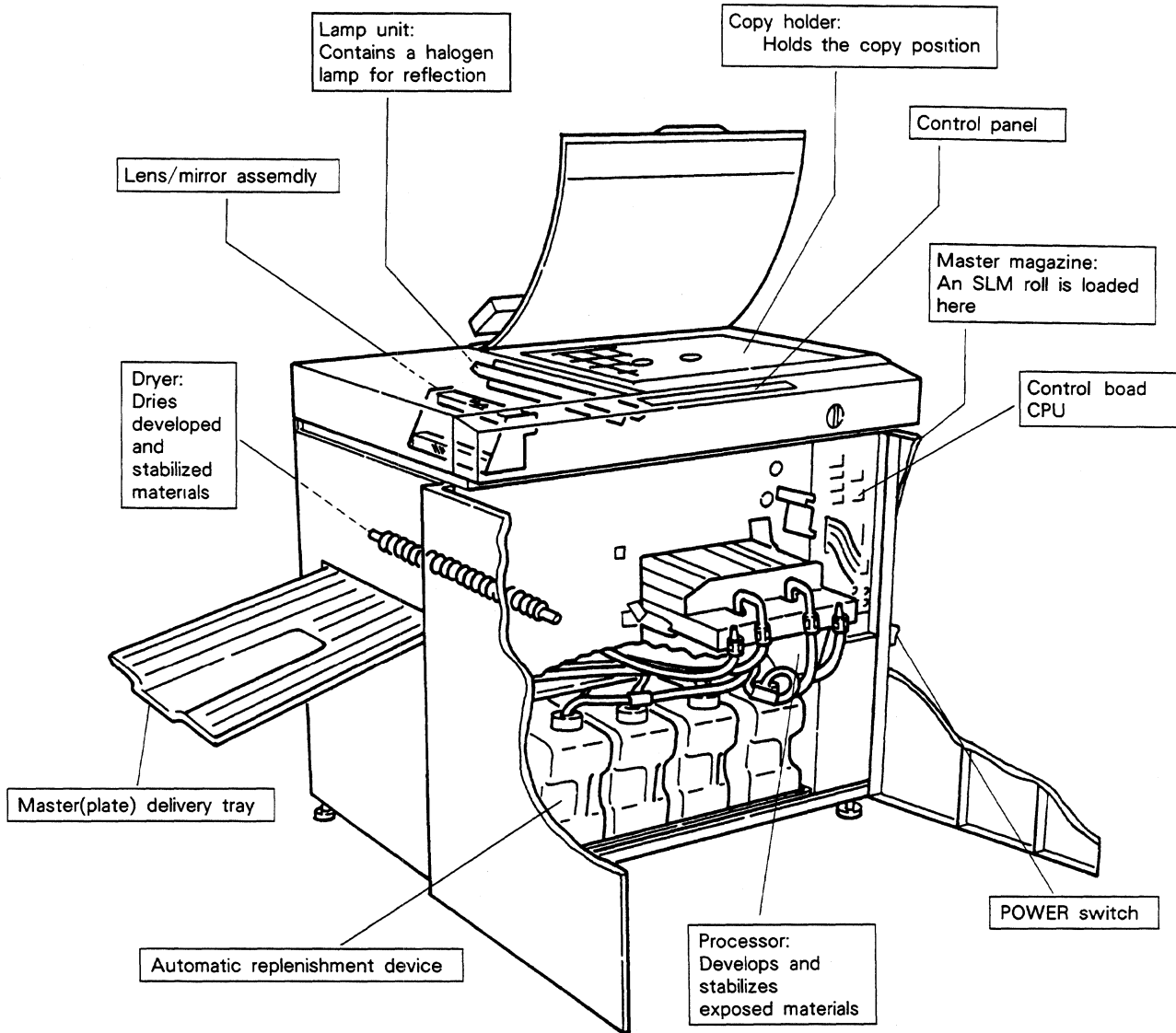

7.2 Description of the Components

7.2.1 Power switch

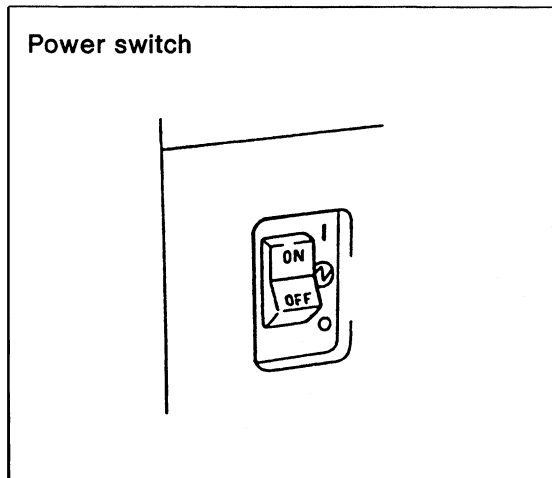

When this switch is turned on, the control circuit, processor motor, dryer, panel heater, etc. also come on and various items to be checked appear in sequence on the display. The operator must then carry out the necessary checks for start-up. Display of one item lasts five seconds.

NOTE : Nothing appears on the display for one second after the power is turned on.

CAUTION : If there is an abnormal sound during photographing, immediately turn off the POWER switch.

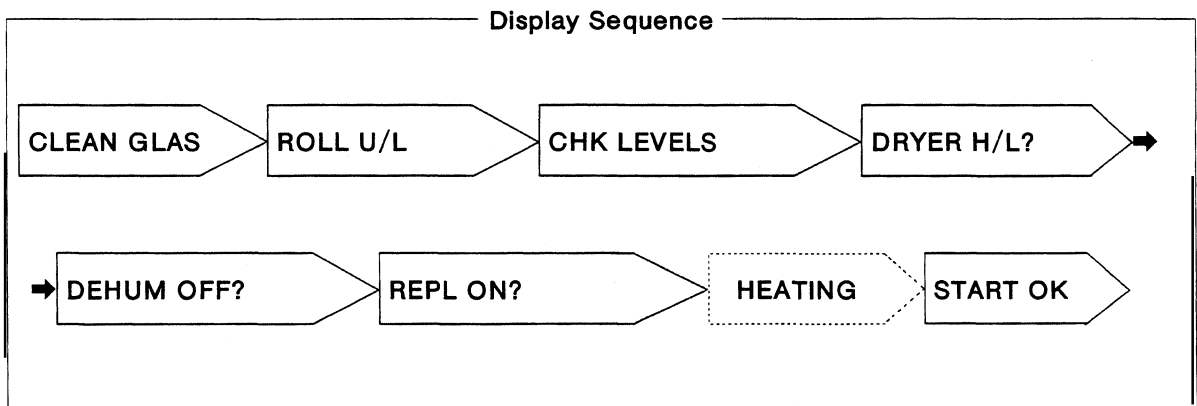

To stop the display, press the start key. For restart, press clear key (**C**).

CAUTION

CHK LEVELS→

Make sure there is a sufficient amount of replenisher in each replenisher container!

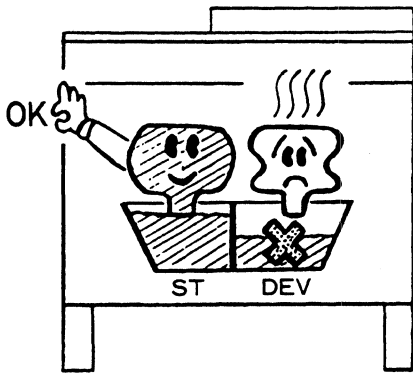

After a large number of plates have been made on the machine or the machine has been shut down for many hours, the processing solutions become exhausted or evaporated, resulting in low liquid levels.

NOTE : When checking processing solutions, see if there is a sufficient amount of replenisher in each replenisher container. If not, add replenisher.

If the automatic replenishment device (option) is used, check the liquid level in each processor tank. If the liquid level is not high enough, add replenisher up to the overflow. For the method of pouring replenishers, see p.44.

7.2.2 Control panel

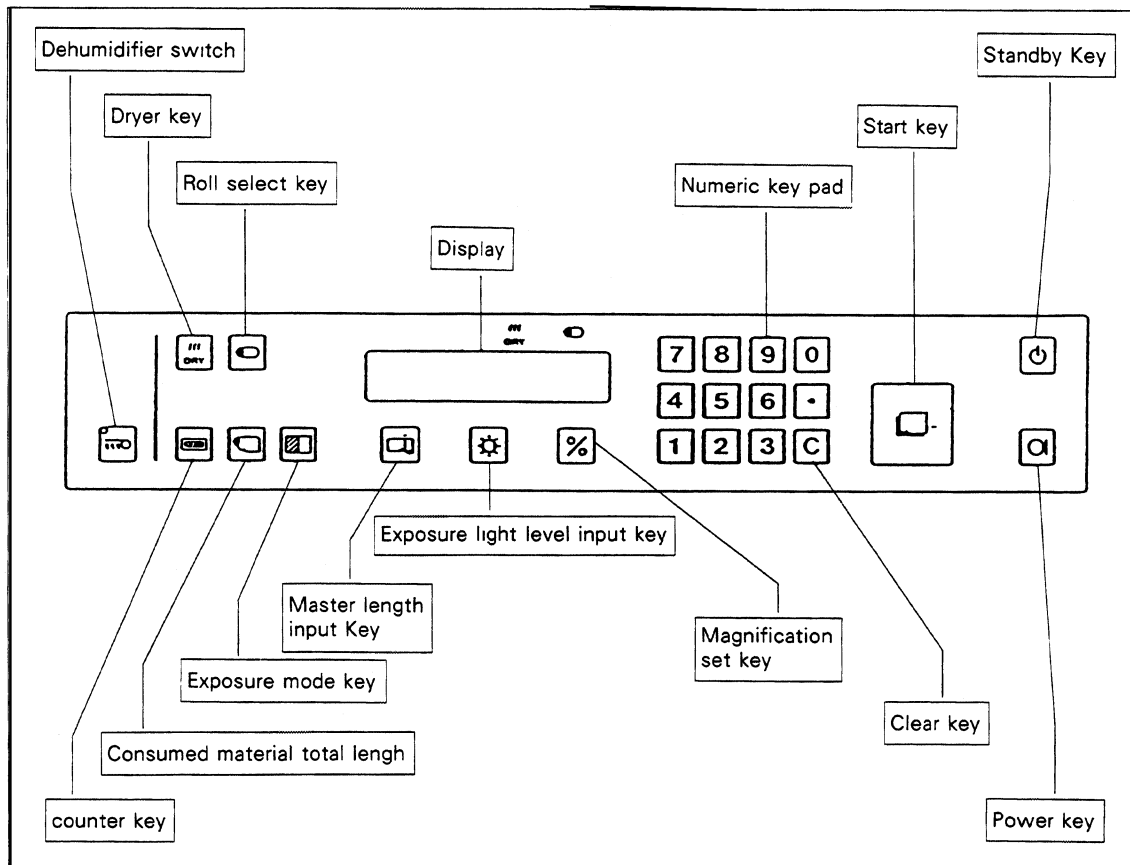

Standby key

This key is used to save electric power when operation of the machine is stopped temporarily for some reason.

To cancel the standby state, press the switch again. "STAND BY" appears on the display and the copy holder moves to its retracted position.

Automatic power saving

If no key entries are made for ten minutes, the buzzer sounds intermittently (pi, pi, ...) to indicate that the machine is going automatically into its power saving standby state. If the standby key is pressed again, the copy holder returns to its home position.

CAUTION : Don't touch the top cover on the delivery side or place anything on it.

O Power key

When this key is pressed to terminate operation, the copy holder returns to its retracted position and the items for the shut-down checkup appear sequentially on the display. During this checkup, the item which is now being checked is displayed for 5 sec.

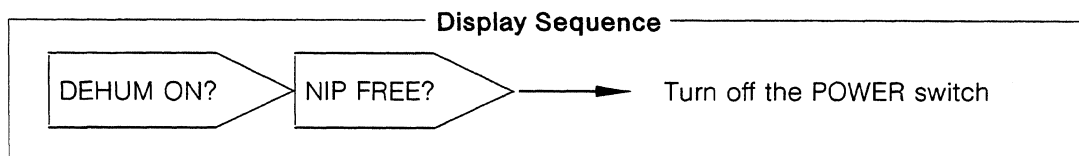

CAUTION : To keep the dehumidifier switch on, don't turn off the POWER switch.

□ Start key

If this key is pressed while "START OK" is on display, the machine starts the platemaking operation. The key also functions as follows:

- i) When pressed during the start-up or shut-down checkup display, the display state at that moment is held. To clear it, press **C**
- ii) Multiple-exposure mode can be started only after the preceding plate has been completely delivered from the machine. If this key is pressed before complete delivery of the preceding plate, the following messages will appear:

TRANSPORT
WAITING

0 ~ **9** Numeric keys

These keys are used to enter various numerical data.

C Clear key

This key is used not only for cancellation, but also for the following purposes:

- i) To clear entry errors ("SETUP ERR")
- ii) To stop the sounding of the buzzer when the material is exhausted (the roll is replaced)
- iii) To stop operation for altering data or any other reason.
When the key is pressed, the light source goes out after a minimum of 225mm /8.86" length material has been fed. The material is then cut, and the copy holder returns to the home position.
- iv) To speed up the item-to-item shift on the start-up or shut-down checkup display
CAUTION : When the "WARM UP" message is cleared, the processing solution may not reach an adequate processing temperature; so in this case, turn off the power key once and turn it back on.
- v) To stop the copy lighting which helps place the copy in position



Master length input key

- i) Enter the desired master(plate) length data (in mm) using the numeric key pad, and then press this key. The master length data entered appears on the display.
CAUTION : If data outside the permissible setting range (225 - 580) is entered, the message "SETUP ERR" appears on the display. Press the clear key for reentry.
- ii) Serves as a data input key in the Multiple Exposure Mode.



Exposure light level input key / Copy lighting key

- i) Manual exposure light level setting
Enter the desired exposure light level data (0 - 99) using the numeric key pad, and then press this key. The exposure level entered appears on the display.
(The suggested light level is 40 to 60, though it depends on the copy image density level.)
Setting larger numbers increases the light level while setting smaller numbers decreases it.
NB : If zero is set, the LED light source will not light, thus resulting in complete non-exposure.
- ii) Automatic exposure light level setting
The suitable exposure light level is automatically set depending on the magnification used, with respect to the basic exposure light level for 100%.
- iii) Copy lighting
When this key is pressed, the light illuminates for 30 seconds, to help the operator position the copy accurately. To turn off the light, press **C**



Magnification set key

- Enter the desired magnification ratio (50 -105%) using the numeric key pad (in 0.1% increments). Then press this key to store and display magnification data.
NB : If the input data is not within the permissible magnification range, "SETUP ERR" will appear on the display. To clear this message, press **C**



Dryer key

- This key is used to choose high or low temperature for the dryer heater. The choice should be made depending on the degree of wetness of the plate.
HIGH : Choose HIGH when the atmospheric temperature is low and the plates which have passed the dryer don't seem sufficiently dry or when the Silver Master F (SLM-F) is used.
LOW : Choose LOW when the Silver Mister RII is used.



Consumed material total length key



START OK	L	U	4 1 4
0 0 7 5 cm (29.52")	5 0	1 0 0.	0 %

The total length of the material consumed so far is displayed for each of the upper and lower rolls in the magazine while this key is held pressed.

e.g.) "0075cm":75cm ("29.52" = 29.52inch) of material consumed

NB : To select the upper or lower roll, use the roll select key 

To reset the display:

- i) Press  +  (the display turns to "0000".)
- ii) If the material is exhausted, the display is automatically reset.





Counter key

START OK	L	U	4 1 4
0 1 0 7	5 0	1 0 0.	0 %

While this key is held depressed, the total number of plates so far made from both the upper and lower rolls in the magazine appears on the display.

e.g.) "0107": means that 107 plates have been made so far.

To reset the counter:

- i) press  +  .
The display returns to "0000".



Dehumidifier switch

This switch is used to turn on or off the dehumidifier (defogger).

Depending on the atmospheric conditions, the device is used to dehumidify the inside of the machine and to prevent condensation due to sudden temperature changes.

To run the device at night, turn off the  power key; don't turn off the POWER switch.



Roll select key

- i) Enter the width and type of the Silver Master roll (R11 or F) you are going to use, using the numeric key pad, and press this key. The input data will appear on the display.
- ii) Use this key to select either the upper or the lower roll (each time the key is pressed, the rolls switch round).
- iii) As the material is exhausted, a new roll is automatically loaded by using this key.

Roll width input

e.g.: When you are going to select the Silver Master F (SLM-F) of 414mm/16.3" in width as the "lower (L)" roll:

START OK	L	L	
5 0 0 mm (19.69")	5 0	4 1 4 .	



START OK	L	L	4 1 4 F
5 0 0 mm (19.69")	5 0	1 0 0 .	0 %

Press the appropriate key as follows and select L .

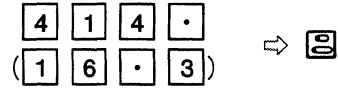

When choosing Silver Master RII(SLM-RII), press the appropriate

key as follows:

4	1	4	
(1	6	.	3)

 ⇒ 

Automatic material setting

This function automatically moves and sets the material to the optical axis position when the roll is exhausted or when the roll is reloaded.

A. Automatic setting for the selected roll B. Automatic setting for the non-selected roll

(A new roll for the lower position is set while the paper roll is being used)

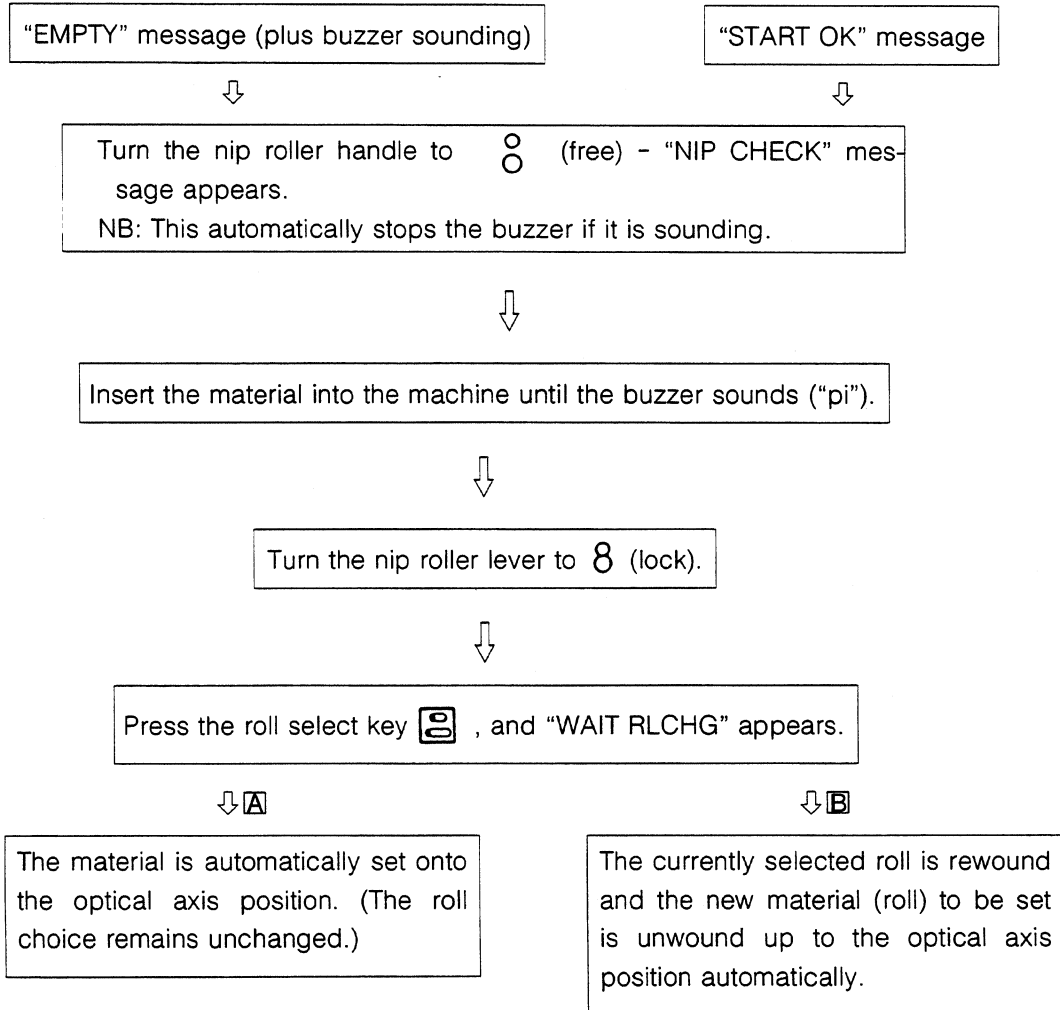

- CAUTION :
1. If [key icon] is pressed at point A while "EMPTY" is on display, normal roll replacement will be made.
 2. If new rolls are loaded for both the upper and lower rolls after the EMPTY message, the selected roll is automatically set onto the optical axis position.

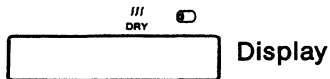

1. The display shows the condition of the machine in operation and error messages.

- | | |
|---|--|
| A. EMPTY (the buzzer sounds)..... | There is no material, or the roll is exhausted. |
| B. COPY POSIT | The copy holder is not at its home position.
NB: See 10.TROUBLESHOOTING. |
| C. CUTTER ERR | The cutter assembly is not at its home position.
NOTE: See 10.TROUBLESHOOTING |
| D. SETUP ERR | The input data is out of the permissible setting range. |
| E. WARM UP | The temperature of the processing solution is below the preset level. |
| F. WAITING (the buzzer sounds intermittently) | A material splice is being detected. |
| G. TRANSPORT | The material is being delivered from the machine. |
| WAITING | |
| H. CHK REPL | The automatic replenishment device is being checked. |
| I. DOOR! | Close the machine front cover and delivery side top cover. |
| J. REPLENISH | SOLUTION (the buzzer sounds intermittently)Add replenisher. |
| K. REPL IN | Replenishment is being made. |
| WAITING | |
| L. CHECK | PROCESSOR (the buzzer sounds)
Check the processor. |
| M. START OK | The machine is ready for operation |
| N. NIP CHECK | The nip roller handle is at (free).
○
○ |
| O. GRIPPER? | Enter the gripper margin value for multiple exposure. |

- P. EXP. L.? Enter the exposure length for multiple exposure.
- Q. TOTAL L.? Enter the total plate length for multiple exposure with gripping margin at the top edge.
- R. STAND BY The automatic power saving function works.
- NB : See the description of the standby key (p.).

2. Condition check (at startup and shutdown) item display
3. Exposure light level data display
4. Master length data display
5. Dryer high-low display
6. Upper/lower roll choice display
7. Double/multiple exposure mode display
8. Other data display
9. Maintenance display (When the maintenance function is morning)



Exposure mode key

This key is used to select the exposure mode (standard, double or multiple division).
The following seven modes are available:

- Standard mode -

START OK	L	U	4 1 4
			(16.30)
5 0 0 mm	5 5	1 0 0.	0 %
(19.69")			

- Side gripping margin mode -

GRIPPER?		SIDE	0 4 0
			(1.57)
5 0 0 mm	G S	5 5	1 0 0. 0 %
(19.69")			

- Double exposure mode with side gripping margin -

GRIPPER?		2 DIV	0 5 0
			(1.97)
5 0 0 mm	G S	5 5	1 0 0. 0 %
(19.69")			

- Multiple exposure mode with side gripping margin -

GRIPPER?		DIV	0 4 0
			(1.57)
5 0 0 mm	G S	5 5	1 0 0. 0 %
(19.69")			

- Top edge gripping margin mode -

GRIPPER?		TOP	0 2 3
			(0.91)
5 0 0 mm	G T	5 5	1 0 0. 0 %
(19.69")			

- Double exposure mode with top edge gripping margin -

GRIPPER?		2 DIV	0 3 0
			(1.18)
5 0 0 mm	G T	5 5	1 0 0. 0 %
(19.69")			

- Multiple exposure mode with top edge gripping margin -

GRIPPER?		DIV	0 5 3
			(2.09)
5 0 0 mm	G T	5 5	1 0 0. 0 %
(19.69")			

Press  once.



Press  again (second time).

NB1 : The number of times the  key has been pressed is counted from the standard mode screen.

NB2 : The standard exposure mode screen is restored by pressing

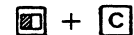

Press again (third time).



Press again (fourth time)



Press again (fifth time)



Press again (sixth time)

Side gripping margin mode

****Making an exposure in the center along the master(plate) length where the side edge area is taken as the gripping margin.****

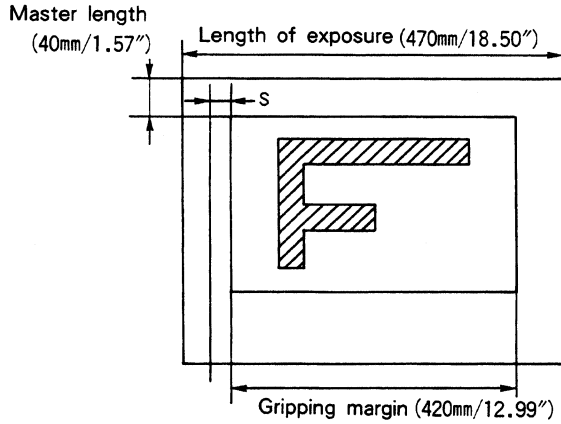

START OK	L	U	4 1 4
			(16.30)
4 7 0 mm	5 0	1 0 0.	0 %
(18.50")			



GRIPPER?	SIDE	0 4 0
		(01.57)
4 7 0 mm	G S	5 0
(18.50")		4 0
		(1.57)



EXP. L.?	SIDE	4 2 0
		(12.99)
4 7 0 mm	G S	5 0
(18.50")		4 2 0
		(12.99)



START OK	SIDE	1 6 7
		(06.58)
4 7 0 mm	G S	5 0
(18.50")		1 0 0.
		0 %

On the standard exposure mode screen:

- Enter "MASTER LENGTH" and "MASTER WIDTH".

NB : For the side gripping margin mode, never forget to enter the master(roll) width.

On the side gripping margin mode screen:

- Enter "GRIPPER" data

4 0
(1 . 5 7) ⇒

040 : The gripping length is (01.57) displayed while is held depressed

- Enter "EXP. L." data

4 2 0
(1 2 . 9 9) ⇒

420 : The exposure length is (12.99) displayed while is held depressed.

- Place the copy in position and press the start key.

NB : The copy set position 167 (06.58) is calculated from the input gripping length and master width, and displayed. Set the copy along this specified position.

The exposure length can also be altered on the START OK screen.

Exposure at a magnification of 80%

START OK	L	U	4 1 4
			(16.30)
4 7 0 mm	5 0	1 0 0.	0 %
(18.50")			



START OK	L	U	4 1 4
			(16.30)
4 7 0 mm	4 3	0 8 0.	0 %
(18.50")			



GRIPPER?	SIDE	0 4 0
		(01.57)
4 7 0 mm	G S 4 3	0 8 0.
(18.50")		0 %



EXP. L.?	SIDE	3 3 6
		(13.32)
4 7 0 mm	G S 4 3	0 8 0.
(18.50")		0 %



START OK	SIDE	2 0 8
		(08.22)
4 7 0 mm	G S 4 3	0 8 0.
(18.50")		0 %

On the standard exposure mode screen:

- Alter the magnification

8 0 ⇒ **%**

On the side gripping margin mode screen:

- Enter "GRIPPER" data

4 0
(1 . 5 7) ⇒ **[]**

040 : The gripping length is (01.57) displayed while **[]** is held depressed.

Entry "EXP. L." data

3 3 6
(1 3 . 2 3) ⇒ **[]**

336 : The exposure length is (13.23) displayed while **[]** is held depressed.

Entry of "EXP. L." data
copy length (420mm)X0.8 (80%)
= 210mm (13.23inch)

- Place the copy in position and press the start key.

NB : The copy set position 208 (08.22) is calculated from the input gripping length and master width, and displayed. Set the copy along this specified position.

The exposure length can also be altered on the START OK screen.

How to position the copy for the side gripping margin mode

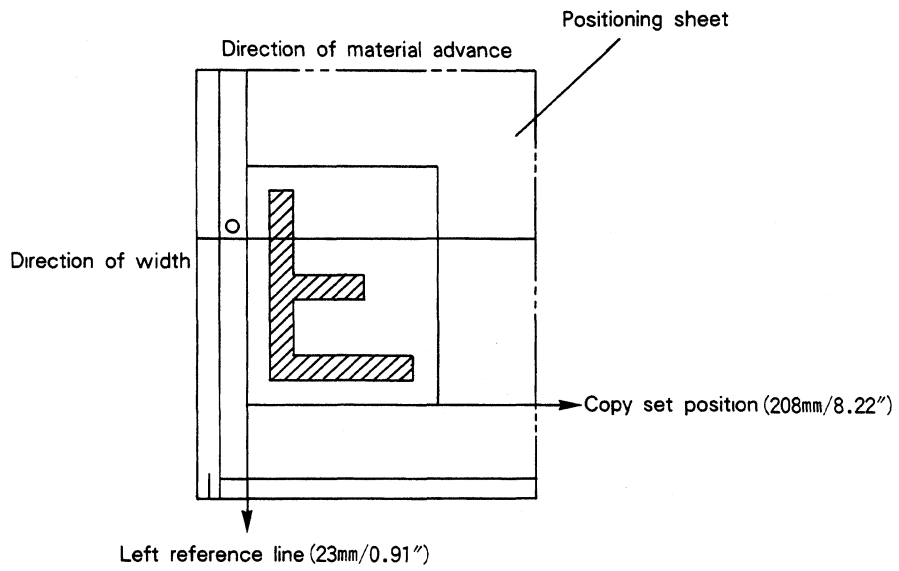

-Direction of advance-

Align the copy edge to the left reference (23mm /0.91") line.

-Direction of width-

Place the copy edge along the copy set position (distance from the centerline,towards the front).

Double exposure mode with side gripping margin

Making two exposures of the same image in equally divided parts with respect to the centerline of the master length

- Double exposure for gutter cutting
- How to position the copy-

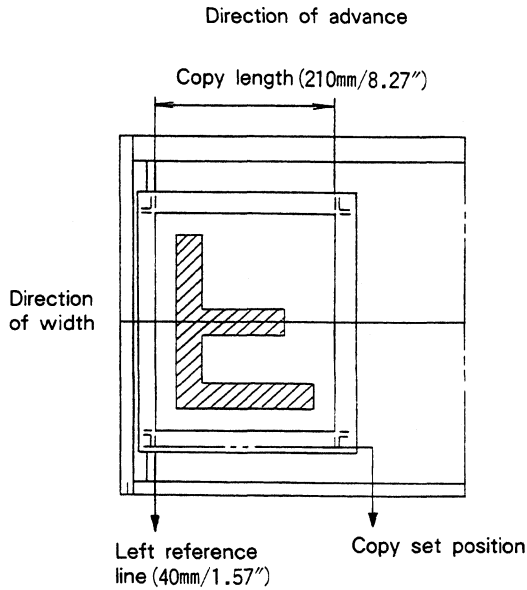

Direction of advance:

- Place the cut line along the left reference line (40mm /1.57" line)

Direction of width:

- Place the copy along the copy set position (distance from the centerline, toward the front)

-The way exposures are made on a plate-

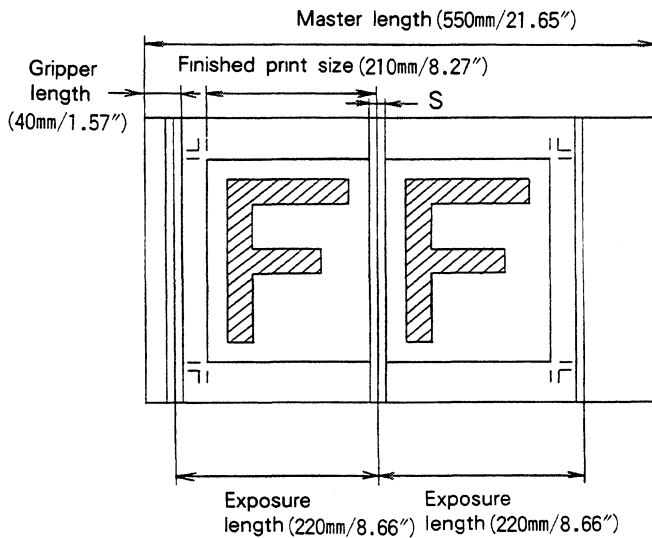

S: slit width

Exposure length = finished print size + 10mm (0.39")

(If the image is as large as the entire exposure length, the part of the image corresponding to the slit width (6mm /0.24" will not be printed.)

START OK	L	U	4 1 4
			(16.30)
5 5 0 mm	5 0	1 0 0.	0 %
(21.65")			



GRIPPER?	2 DIV	0 4 0
		(01.57)
5 5 0 mm GS	5 0	4 0
(21.65")		(1.57)



EXP. L.?	2 DIV	2 2 0
		(08.66)
5 5 0 mm GS	5 0	2 2 0
(21.65")		(8.66)





START OK	2 DIV	1 6 7
		(06.58)
5 5 0 mm GS	5 0	1 0 0.
(21.65")		0 %

On the standard exposure mode screen:

On the side gripping double exposure mode screen:

Enter "GRIPPER" data.

4 0
(1 . 5 7) ⇒ 

040 : The gripping length is (01.57) displayed while  is held depressed.

Enter "EXP. L." data.

2 2 0
(8 . 6 6) ⇒ 

220 : The exposure length is (08.66) displayed while  is held depressed.

Place the copy along the copy set position 167(06.58) and press the start key.

The exposure length can be altered even on the START OK screen.

- Exposure at a magnification of 50%

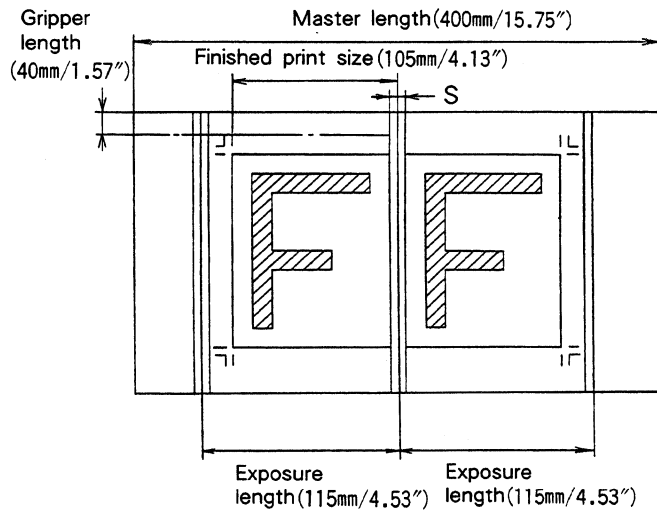

Enter "EXP. L.?" data.

copy length (210mm /8.27") ×
0.5 (50%) + 10mm /0.39" =
115mm (4.53")

- Double exposure for trimming
 - How to position the copy-

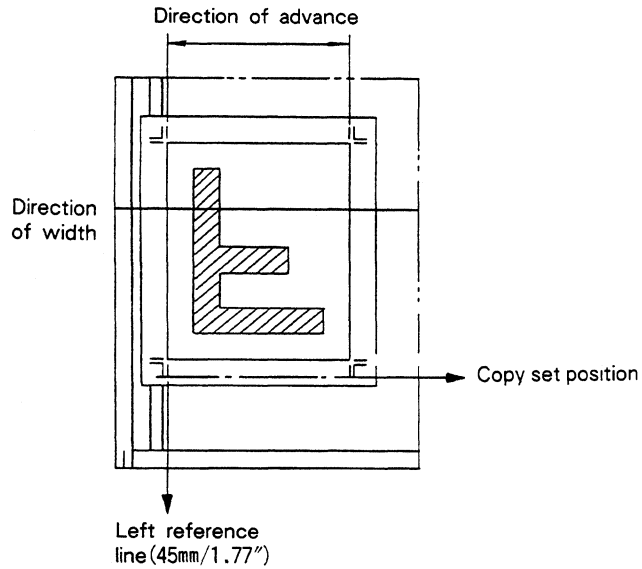

Direction of advance:

- Place the cut line along the left reference line (45mm /1.77" line)

Direction of width:

- Place the copy along the copy set position (distance from the centerline, toward the front)

-The way exposures are made on a plate-

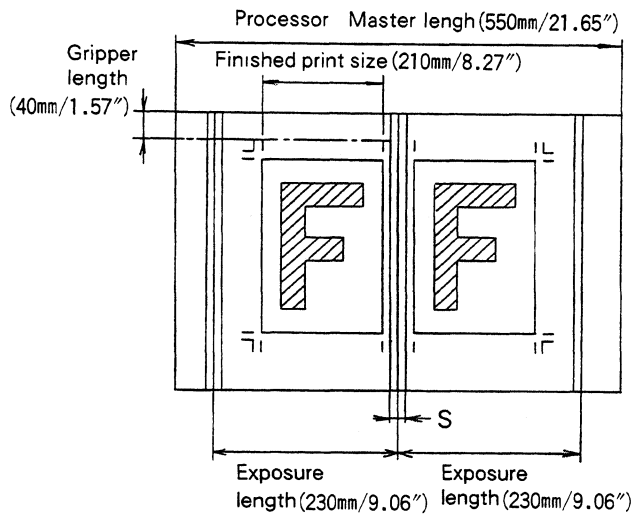

S : slit width

Exposure length = finished print size + 20mm (0.79")

GRIPPER?	2 DIV
5 5 0 mm GS 5 0	4 0
(21.65")	(1.57)



EXP. L.?	2 DIV
5 5 0 mm GS 5 0	2 3 0
(21.65")	(9.06)



START OK	2 DIV	1 6 7
5 5 0 mm GS 5 0	1 0 0 . 0 %	(06.58)
(21.65")		

On the side gripping double exposure mode screen:

Enter "GRIPPER" data.

⇒ 

Enter "EXP. L." data.

⇒ 

Place the copy along the copy set position 167(06.58) and press the start key.

The exposure length can be altered even on the START OK screen.

- Exposure at a magnification of 80%

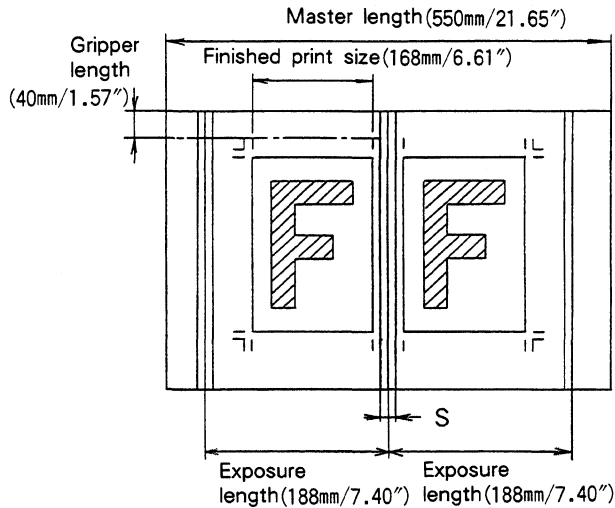

Enter "EXP. L." data
 copy length (210mm /8.27") ×
 0.8 (80%) + 20mm /0.79" =
 188mm /7.40"

Multiple exposure mode with side gripping margin

Making several exposures in the center along the master length

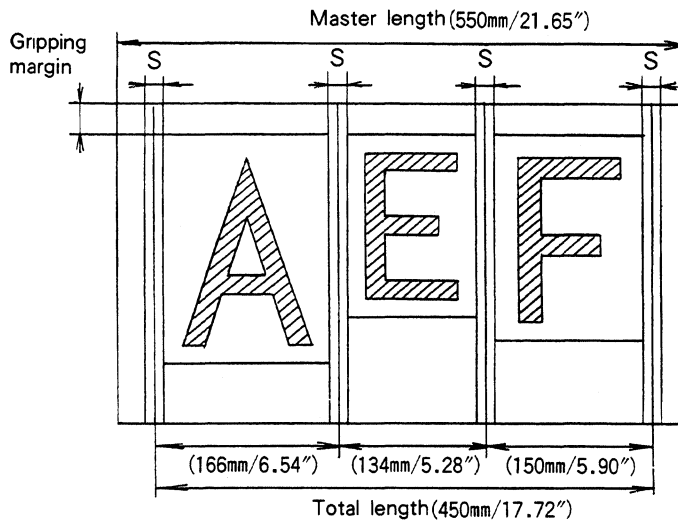

If a magnification below 74.8% is used for multiple exposure and the input exposure length is below 40mm/1.57", normal exposures will not be made.

- Multiple exposure of characters A (100%), E (80%) and F (90%) -

On the side gripping Multiple exposure mode screen:

GRIPPER?	DIV
5 5 0 mm GS 5 0 (21.65")	4 0 (1.57)



TOTAL L?	DIV
5 5 0 mm GS 5 0 (21.65")	4 5 0 (17.72) 4 5 0 (17.72)



EXP. L?	DIV
5 5 0 mm GS 5 0 (21.65")	1 6 6 (6.54)



START OK	DIV
5 5 0 mm GS 5 0 (21.65")	1 6 7 (06.58) 1 0 0 . 0 %



- Enter "GRIPPER" data

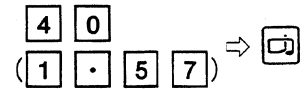

- Enter "TOTAL L." data.



450 : The total length is
(17.72) displayed while [OK] is held depressed.

- Exposure of character A at 100% -

- Enter "EXP. L." data.

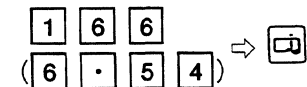

- Place the copy along the copy set position (167mm /6.58") and press the start key.

EXPOSING	DIV	1 6 6
		(06.54)
2 8 4 mm GS 5 0	1 0 0.	0 %
		(11.18")



START OK	DIV	2 0 8
		(08.22)
2 8 4 mm GS 4 3	0 8 0.	0 %
		(11.18")



START OK	DIV	2 0 8
		(08.22)
2 8 4 mm GS 4 3	1 3 4	
		(5.28)



EXPOSING	DIV	1 3 4
		(5.28)
1 5 0 mm GS 4 3	0 8 0.	0 %
		(05.90")



START OK	DIV	1 8 5
		(07.31)
1 5 0 mm GS 4 7	0 9 0.	0 %
		(05.90")



START OK	DIV	1 8 5
		(07.31)
0 GS 4 7	0 9 0.	0 %
		(00.62")

- An exposure of character A is being made.

284 : means the sum (remaining length) of character E exposure + character F exposure

-Exposure of character E at 80%-

- Alter the magnification

⇒

208 : the copy set position for (08.22) 80%

- Enter "EXP. L." data.

⇒

- Place the copy along the specified set position (208mm/8.22") and press the start key.

- An exposure of character E is being made.

150 : means the remaining length for character F exposure

-Exposure of character F at 90%-

- Alter the magnification

⇒

185 : the copy set position for (07.31) 90%

- Enter "EXP. L." data.

⇒

- Place the copy along the specified set position (185mm /7.31") and press the start key.

Top edge gripping margin mode

****Making an exposure with gripping margin at the plate leading edge****

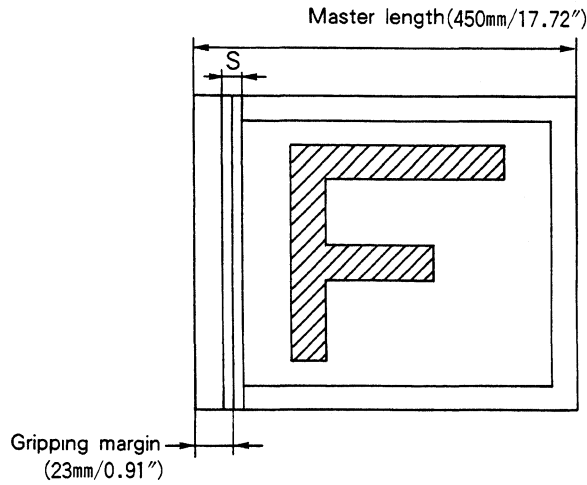

S: slit width (6mm)

The input gripping length should within a range of 23mm - 99mm. (0.91" - 3.89")

On the top edge gripping margin mode screen:

GRIPPER?	TDP	0 2 3
		(0.91)
4 5 0 mm G T 5 0		2 3
(17.72")		(0.91)

- Enter "GRIPPER" data.

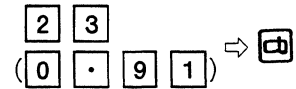

023 : The gripping length is (0.91) displayed while is held depressed.



START OK	TDP	0 2 3
		(00.91)
4 5 0 mm G T 5 0 1 0 0 . 0 %		
(17.72")		

- Place the copy in position and press the start key.

How to position the copy for the top edge gripping margin mode

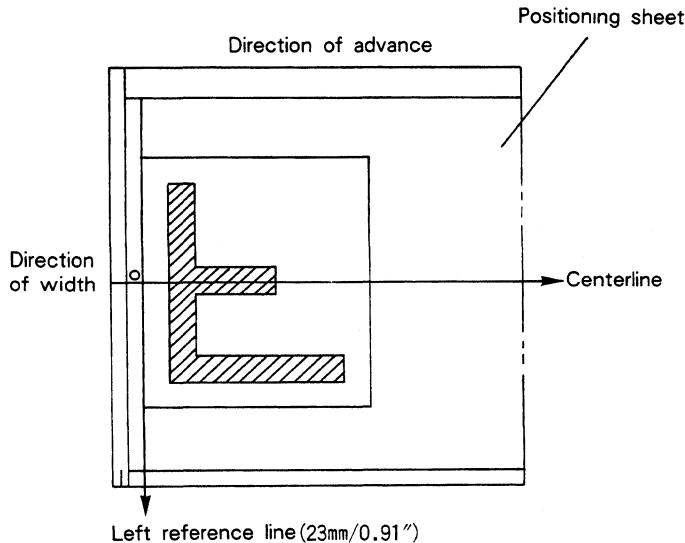

- Direction of advance-
Align the copy edge to the left reference (23mm /0.91") line
- Direction of width-
Place the copy in the center.

Double exposure mode with top edge gripping margin

Making an exposure with gripping margin at the plate leading edge

- Double exposure for gutter cutting
- How to position the copy-

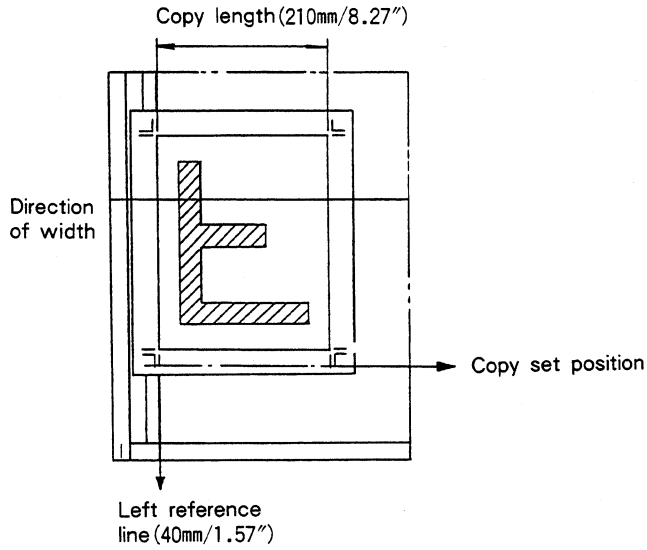

-The way exposures are made on a plate-

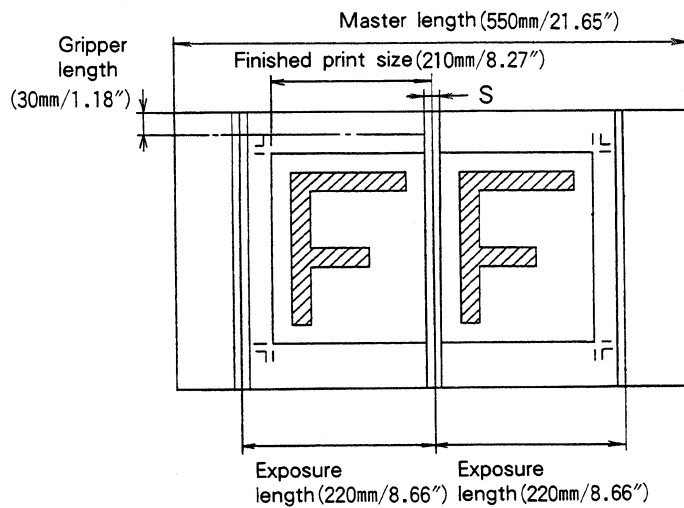

S: slit width

Exposure length = finished print size + 10mm /0.39"

On the standard exposure mode screen:

START OK	L	L	4 1 4
			(16.30)
5 5 0 mm		5 0	1 0 0. 0%
(21.65")			



On the top edge gripping double exposure mode screen:

GRIPPER?		2 DIV	
5 5 0 mm	GT	5 0	3 0
(21.65")			(0.91)

Enter "GRIPPER" data.

3	0
0	·
9	1

 ⇒ 



Enter "EXP. L." data.

EXP. L.?		2 DIV	2 2 0
			(08.66)
5 5 0 mm	GT	5 0	2 2 0
(21.65")			(8.66)

2	2	0
8	·	6
6		6

 ⇒ 



Place the copy and press the start key.

START OK		2 DIV	2 2 0
			(08.66)
5 5 0 mm	GT	5 0	1 0 0. 0%
(21.65")			

The exposure length can be altered even on the START OK screen.

- Double exposure for trimming
- How to position the copy-

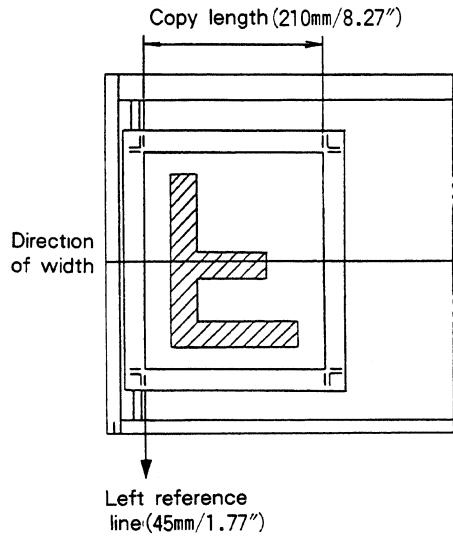

Direction of advance :

- Place the cut line along the left reference line (45mm /1.77" line)

Direction of width:

- Place the copy in the center.

-The way exposures are made on a plate-

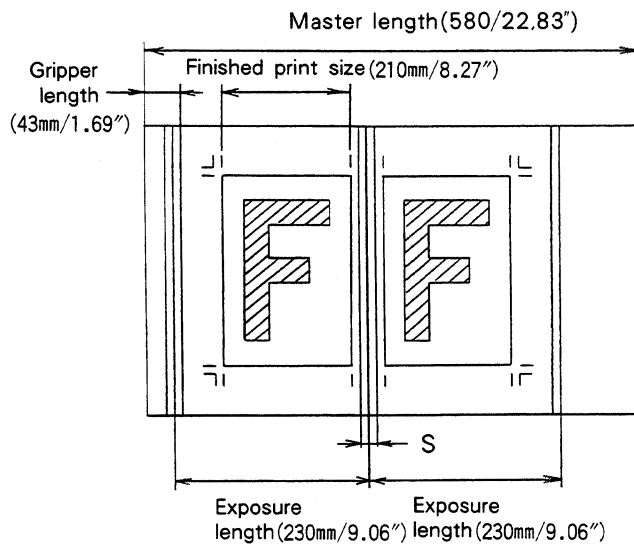

S: slit width

Exposure length = finished print size + 20mm (0.79")

On the top edge gripping double exposure mode screen:

GRIPPER?	2 DIV
5 8 0 mm GT 5 0	4 3
(22.83")	(1.69)

Enter "GRIPPER" data.

⇒



EXP. L.?	2 DIV
5 8 0 mm GT 5 0	2 3 0
(22.83")	(9.06)

Enter "EXP. L." data.

⇒



START OK	2 DIV	2 3 0
5 8 0 mm GT 5 0	1 0 0 . 0 %	(09.60)
(22.83")		

Place the copy and press the start key.

The exposure length can be altered even on the START OK screen.

Multiple exposure mode with top edge gripping margin

Making several exposures with gripping margin at the plate leading edge

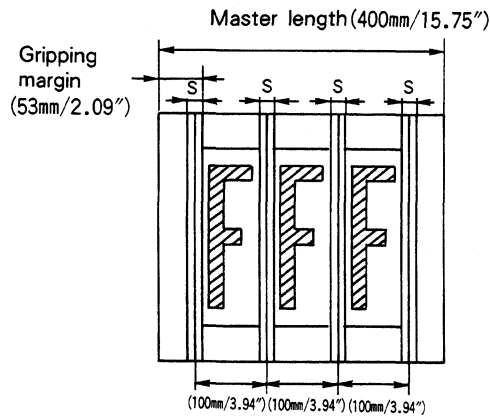

GRIPPER?	DIV
4 0 0 mm GT 5 0 (15.75")	5 3 (2.09)



EXP. L.?	DIV
4 0 0 mm GT 5 0 (15.75")	1 0 0 (3.94)



START OK	DIV	1 0 0
4 0 0 mm GT 5 0 (15.75")	1 0 0 . 0 %	(03.94)

2 5 0 mm (09.84")

1 5 0 mm (5.90")

5 0 mm (1.96")

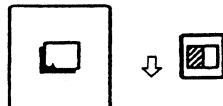

or

On the top edge gripping multiple exposure mode screen:

- Enter "GRIPPER" data.

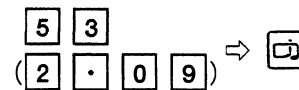

- Enter "EXP. L." data.

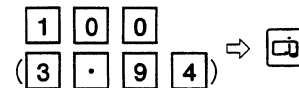

- Place the copy in position and press the start key.

- Each time the start key is pressed, the remaining plate length is displayed.

- After several exposures have been made, if the remaining plate length for the last exposure is equal to the copy length, press the start key for the last exposure. The exposed plate will be automatically delivered from the machine.

If not so, press the exposure mode key.

The exposure length can also be altered even on the START OK screen.

7.3 Copy Holder

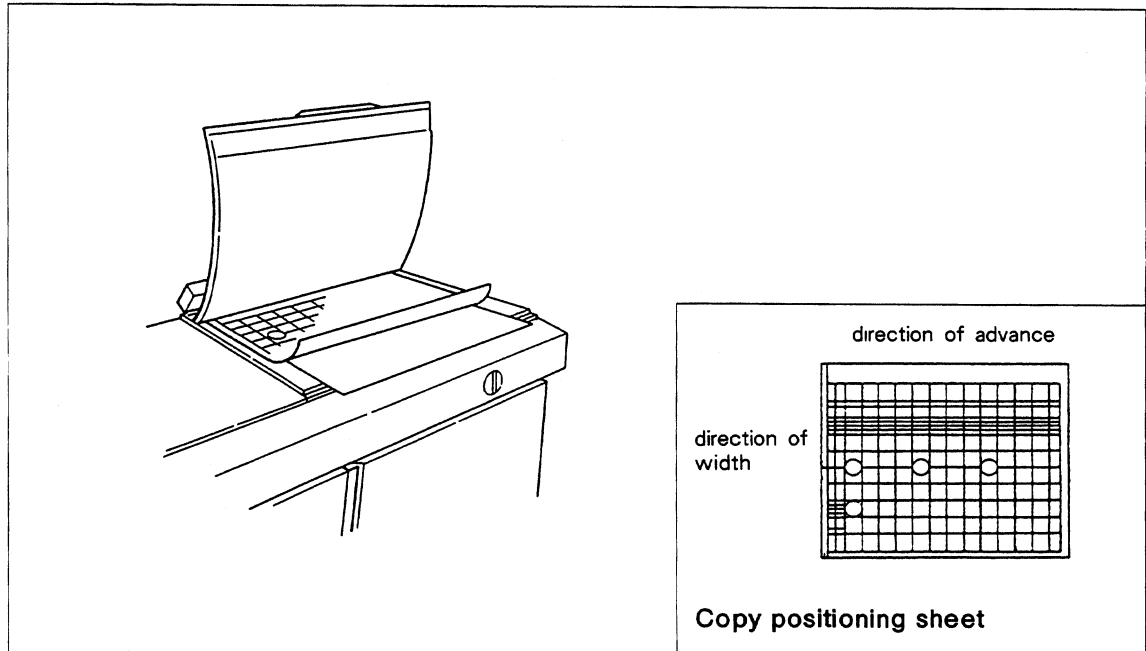

CAUTION : The copy holder moves in the longitudinal direction. Don't put anything on top of the machine.

Don't touch the copy holder while it is in motion.

7.3.1 Loading the copy

- (1) Lift the copy frame slowly holding the frame handle.

Springs cause the frame to stop in a specific open position. (Hold the frame handle until the frame is stationary.)

- (2) Place the copy between the copy positioning sheet and the copy glass.

Close the copy frame gently.

CAUTION : Open and close the copy frame gently; if it is handled abruptly, machine trouble can occur.

7.3.2 Positioning the copy

- (1) The reference line "0" in the copy positioning sheet corresponds to the leading edge of the material.

Since the slit exposure system causes double-exposure at the edges of the material, 23mm /0.91" area at the leading edge and 3mm /0.12" at the trailing edge are ineffective for exposure.

- (2) The sheet is ruled into 5mm /0.19" squares, which permits easy and accurate positioning of the copy.
- (3) There are lines at 1mm /0.04" intervals in the direction of width of the material, which will help you determine the position of the copy for side gripping margin mode exposure.

7.4 Lens-Mirror Assembly

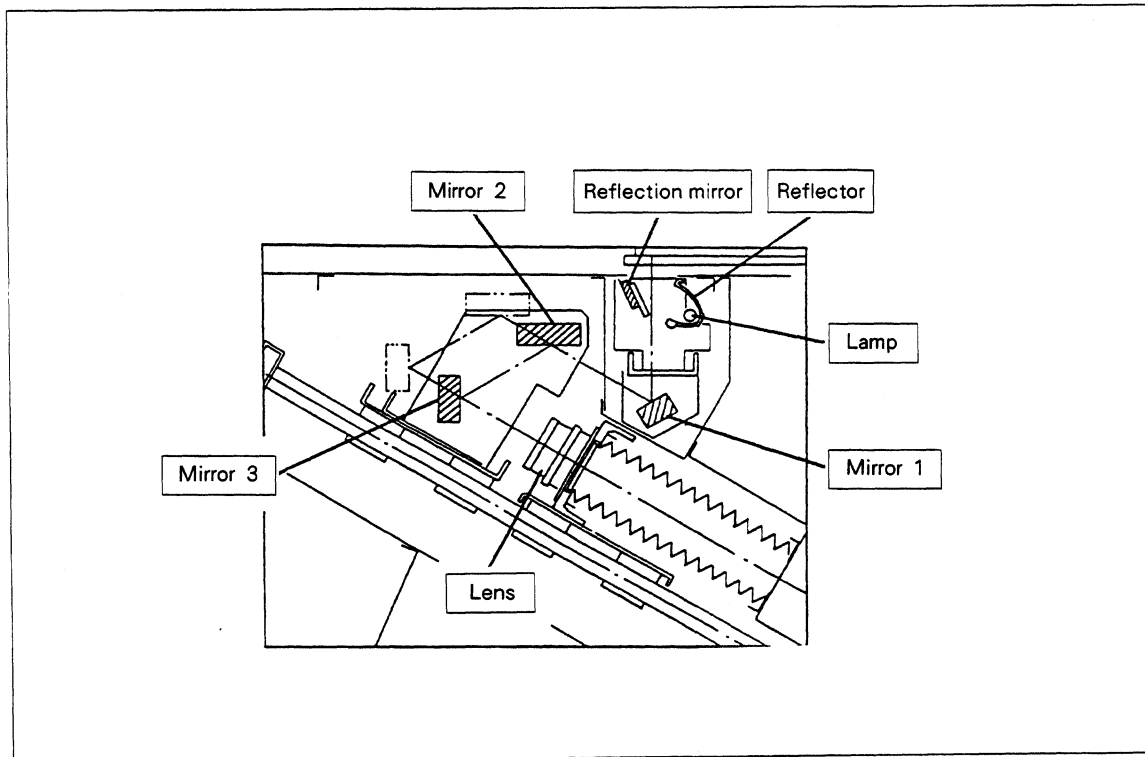

- The light from the copy (image) is reflected by mirror 1; the reflected light strikes upon mirror 2 and then upon mirror 3, and passes through the lens to reach the material.
- The lens and mirrors move to the appropriate positions depending on the magnification (105.0 - 50.0%).

NB1 : The machine should be located in a place with little dust and humidity so that the mirrors are not affected.

NB2 : When replacing the lamp or cleaning the inside of the machine, don't touch the mirrors or lens.

7.5 Photographing Section

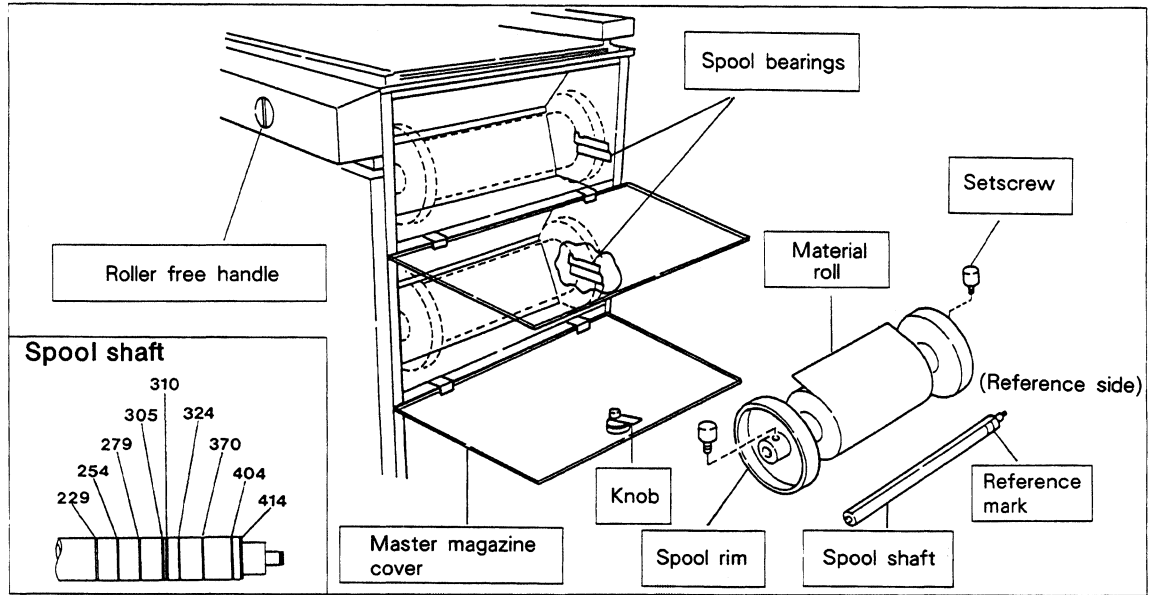

7.5.1 Loading a material roll

7.5.1.1 Silver Master RII (SLM-RII)

- (1) Make sure that there is no material in the roll position in which you are going to load a new roll (or if there is a wound up roll, take it out) and select either the upper or the lower roll using the roll select key.
- (2) Make sure that "EMPTY" appears on the display and the buzzer works properly. Then press the clear key to stop the buzzer.
- (3) Adjust the reference spool rim (right-side marked in red) in the appropriate position on the shaft depending on the width of the roll to be used.
- (4) Put the roll on the spool shaft so that the winding of the roll is clockwise as viewed from the reference spool rim side.
- (5) Attach the other spool rim to the spool shaft and place the spool and roll on the spool bearings.
- (6) Remove the adhesive tape.
- (7) Turn the nip roller lever to the free position.
- (8) For the upper roll, insert the end of the material over the nip roller into the machine; for the lower roll, insert it under the nip roller (between the two rollers). Insert the material end gradually, holding both sides of the roll.
- (9) Insert the material until a beep-sound is heard. From that point, move it further forward approx. 30mm/1.18".
- (10) Keeping one hand on the center of roll and your other hand on the spool, wind it back by approx. 10mm/0.39".
Note: Repeat from step 8 again if spool has been wound back excessively and "EMPTY" has appeared on the display.
- (11) Turn the nip roller lever to the lock position while holding down the center of the material roll lightly by hand.
- (12) Stretch the material to check there is any unevenness in tension or lack of tension.
Note: If the roll is not set properly, repeat from step 8 again.
- (13) Confirm that the "Set Master" message has appeared on the display and press the roll select key.

General precautions:

- When loading a roll in the lower position, be particularly careful to carry out insertion and rewinding of the material properly.
- When unloading the roll, select the opposite roll from the one which you are going to unload (i.e. if you are going to unload the upper roll, select the lower roll with the roll select key and vice versa.)

7.5.1.2 Silver Master F (SLM-F)

- (1) An SLM-F roll is factory attached to shading paper both edge. Don't, remove the paper when loading the roll in the magazine.

CAUTION : If the shading paper should be removed, the SLM-F roll edge part would be exposed or fogged by external light (room light).

Therefore, never remove or loosen the spool.

- (2) For loading an SLM-F roll, follow the same procedure as for loading a Silver Master RII (SLM-RII) roll.
- (3) The SLM F roll has about 2m /78.74" long leader paper for light shielding; remove it before use.

7.5.2 "EMPTY" message

When the master is going to run out while being fed, "EMPTY" appears on the display and the buzzer sounds.

The remaining material is conveyed to the processor to prevent any strips of material remaining in the photographing section.

The material strips in the processor may be removed either by hand, or automatically by pressing the start key after loading a new roll.

7.5.3 Material splice detection

Some material rolls have a splice. If a splice is detected, "WAITING" appears on the display and the buzzer sounds intermittently.

There are two cases of splice detection :

- i) When the length between the material leading edge and the splice, (α), is shorter than 265mm /10.43" :
the material will be transported by $\alpha + 285\text{mm} /11.22"$.
- ii) When the length between the material leading edge and the splice, (α), is 265mm/10.43" or longer :
 - The master will be transported by length α .
 - Then it will be automatically transported by a further 285mm /11.22".

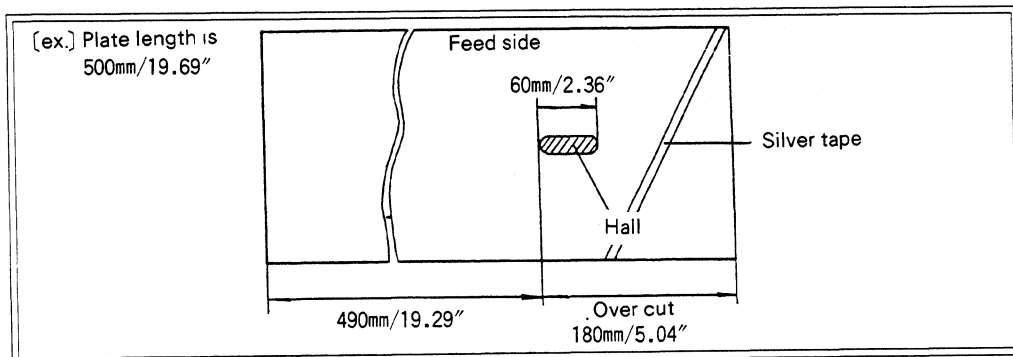

7.6 Processor

When the POWER switch is turned on, the drive motor is started and the conveyor unit rollers turn.

At the same time, the panel heater is activated.

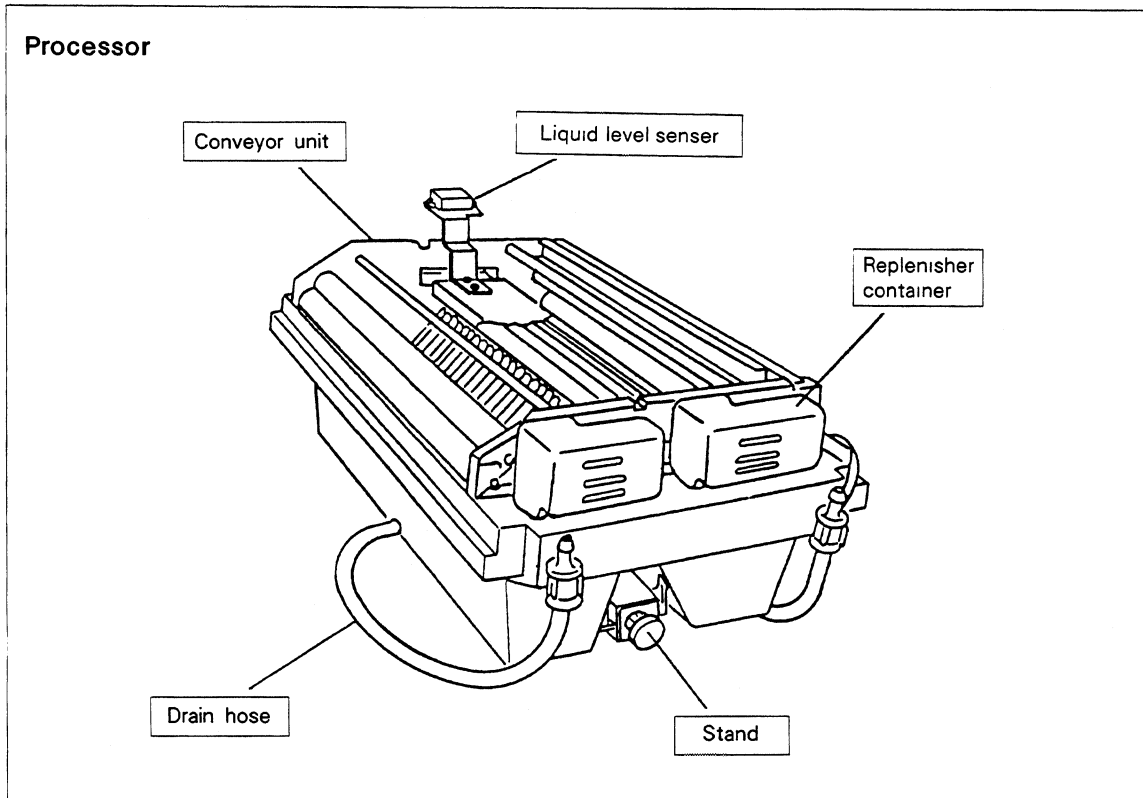

7.6.1 Preparation of processing solutions

- Open the machine front cover, unhook the processor, and pull the processor out of the main body.
- The processor is composed of a tank unit incorporating a developing tank and a stabilizing tank, and an integrated conveyor unit mounted on the tank unit. The developing tank is provided with a 350W panel heater with a built in thermostat so that an activator temperature of around 30°C (86°F) is maintained. After the machine has been out of operation for a long period of time, the conveyor rollers might not turn smoothly since they stick to each other. In such a case, turn the rollers by hand before starting the processor.
- For preparing the processing solutions, use an exclusive measuring cup.
- Use hot water of 30 to 35°C (86 to 95°F) when tap water temperature is low in winter. Be careful not to mix the activator and stabilizer when pouring them since they have an antipathy to each other.

7.6.2 Developing tank (capacity : 7 liters)

Preparation of activator — mixture ratio of SLM-AC to water 1 : 1

- (1) Add 3.5 liters of water to 3.5 liters of SLM-AC (undiluted), exclusive activator for SILVER MASTER, and stir thoroughly. Then pour the mixture into the developing tank.
- (2) Pour the activator prepared in the same ratio (1 : 1) into the activator replenisher container (1 liter), and mount the container properly on the unit.

7.6.3 Stabilizing tank (capacity : 6 liters)

Preparation of stabilizer — mixture ratio of SLM-ST to water 1 : 3

- (1) Add 4.5 liters of water to 1.5 liters of SLM-ST (undiluted), exclusive stabilizer for SILVER MASTER, and pour it into the stabilizing tank after stirring thoroughly.
- (2) Pour the stabilizer prepared in the same ratio (1:3) into the stabilizer replenisher container (1 liter) and mount it properly on the unit.

7.6.4 Replenishment

Each of the replenisher containers should always contain a sufficient quantity of processing solution properly mixed. As the replenishing solution is exhausted, the liquid level in the tank is lowered, resulting in accelerated fatigue of the solution and deterioration in plate quality.

7.6.5 Replacement of the processing solutions

Refer to 9.2 Routine Maintenance.

7.6.6 Control of processing liquid level

If the liquid level in the processor is below the preset level, the following message appears on the display and the buzzer sounds.

NB : The machine cannot be started while the message is on display

REPLENISH SOLUTION

Replenishment procedure





1. Press to turn off the buzzer.
2. Open the machine front cover and pour processing solutions into the tank and replenisher container.
3. Check the liquid level sensor (its up/down motion).

Cautions in Handling Processing Chemicals

- (1) Never drink the processing chemical, or allow them to get in your eyes. (Should such happen, see a doctor.)
- (2) If the processing chemicals get on your skin or clothes, wash promptly and thoroughly in running water.
- (3) Use the processing chemicals correctly as prescribed in the instructions of use.
- (4) Keep chemicals out of reach of children

8. PHOTOGRAPHING

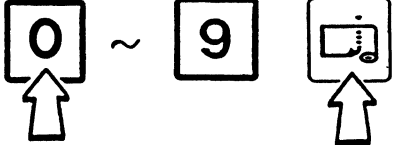
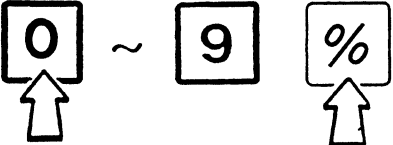
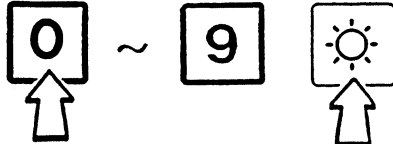
8.1 Photographing Procedure

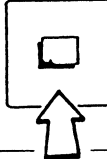
<p>1) Turning on the power switch—start-up checkup Turn on the POWER switch to energize the machine and make it ready for operation.</p>	
<p>2) Roll width selection Enter the master width to be used using the numeric key pad and press the roll select key.</p>	
<p>3) Dryer HIGH/LOW selection Select High or Low with the dryer key depending on the wetness of the plate.</p>	
<p>4) Master length selection Enter the master length data using the numeric key pad and press the master length input key.</p>	
<p>5) Magnification setting Enter the desired magnification ratio (105.0% - 50.0%) using the numeric key pad and enter the magnification set key.</p>	
<p>6) Exposure light level input Enter the exposure light level data suitable for the copy, using the numeric key pad, and press the exposure light level input key.</p>	
<p>7) Standard/double exposure/multiple exposure selection Select one of the three exposure modes — standard, double and multiple — using the exposure mode key.</p>	
<p>8) Positioning the copy Put the copy on the copy glass with its image face down and place it in the required position using the ruling of the copy positioning sheet.</p>	
<p>9) Pressing the start key Press the start key with "START OK" on the display, and exposure starts automatically.</p>	

8.2 How to Determine Standard Exposure

Since the Silver Master is coated with silver-halide emulsion, its sensitivity may vary somewhat among lots. Before using a new lot, check its sensitivity.

Under-exposure may cause a thickened image or scumming on the background of the plate.

Over-exposure may cause a too thin image or lost image.

Correct exposure is essential for the high quality Silver Master SLM-R11 and SLM-F to deliver the best performance.

Refer to the Silver Master Technical Guide.

- (1) The CP-414V is supplied with a test chart and a standard print sample. Make an exposure of the test chart using the photographing procedure stated in 8.1 and compare it with the standard print sample.
- (2) Examine the gray scale in the exposure of the test chart. Adjust the exposure level and determine the level (exposure control setting) for the standard exposure.
 Standard exposure : the exposure where the minimum noticeable silver deposit is seen in the 12th step of the gray scale as in the supplied sample.

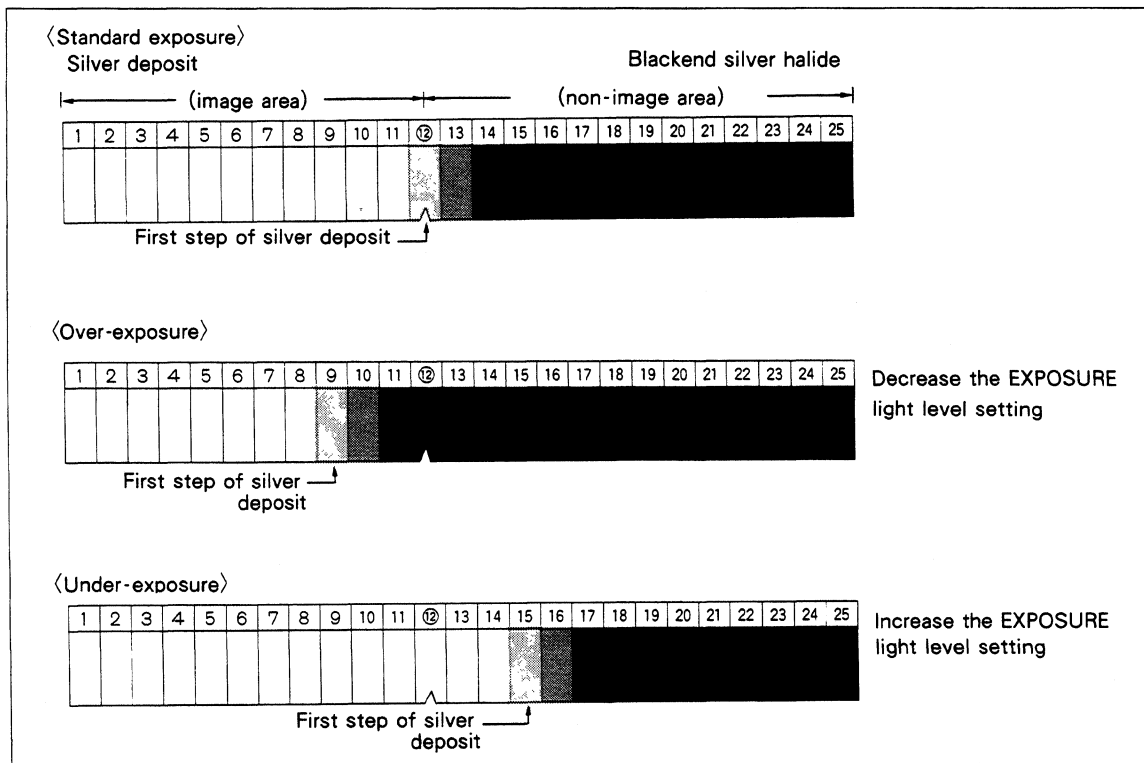

NOTE : The standard print sample may fade with time. Store it in a drawer or dark place.

8.3 How to Determine the Optimum Exposure Level

- (1) The optimum exposure level varies according to the type of original copy being used.
- (2) The optimum exposure level (control setting) differs according to the user's printing conditions (press, printing paper, ink, etc.). The table below shows the suggested exposure control settings for various types of copies. The user should find the best exposure control setting for each copy depending on the individual printing conditions.

Suggested Exposure Control Setting For Various Copies

Copy		Increase/Decrease from Standard Setting
State	Type	
Letters or lines are too thin or blurred.	Written with pencil	0 ~ -20% Decrease to the extent that non-image area does not become whitish.
	Duplication	
Letters are too thick and rough, or darkish back-ground	Photocomposition	-10 ~ +20%
	Typewritten	0 ~ +30% (Increase)
	Halftone	+20 ~ +30% (Increase)













9. MAINTENANCE

The routine maintenance procedures outlined below are necessary to maintain continued satisfactory operation of the machine.

9.1 Maintenance Mode

The maintenance mode is used to check operation of the components or when carrying out routine maintenance.

NOTE : The maintenance mode is used in the "STAND BY" state.

	Check Item	Key Operation	Purpose & Operation
1.	Independent cutter movement	 +  Press numeric key 1 while holding the counter key depressed.	Cutter operation check <ul style="list-style-type: none"> The cutter should move forward (in cutting direction) and reach the return sensor, and then return to the original position
2.	Independent copy holder travel	 +  Press numeric key 2 while holding the counter key pressed. Turn off the POWER switch.  +  Turn on the POWER switch and press numeric key 4 while holding the counter key depressed.	1. Halogen lamp replacement 2. Cleaning the copy glass <ul style="list-style-type: none"> The holder should move to the left and stop when it touches the end sensor. The holder should return (right) to the original position. Unless the end sensor is touched, it should be returned by turning the POWER switch off and back on.
3.	Independent lighting of the halogen lamp	 +  Press numeric key 3 while holding the counter key depressed.	Confirming the lighting of the lamp <ul style="list-style-type: none"> The lamp should light for 5 sec and automatically go out.
4.	Independent lighting of the LED light source	 +  Press numeric key 5 while holding the counter key depressed.	Confirming the lighting of the LED light source for blank exposure <ul style="list-style-type: none"> The lamp should light for 5 sec and automatically go out.
5.	Independent running of the motor for exposure	 +  Press numeric key 6 while holding the counter key depressed.	Running check of the exposure motor <ul style="list-style-type: none"> Press  to stop the motor.

9.2 Routine Maintenance

9.2.1 Processor

1) Frequency of change of processing solutions

One fill of activator or stabilizer is capable of processing 500 plates of B4 size, or 250 plates of A3 size when replenishment is based on liquid level control, and the nominal useful life for activator and stabilizer is 3 weeks. When one of these two limits is exceeded (life span or processing capacity), the solution must be changed regardless of whether the other limit has been exceeded or not.

2) Cleaning the processing tank unit and conveyor unit

Be sure to clean the tank unit and conveyor unit when changing the processing solution. Otherwise, silver, paper powder or chemicals from the plates can stick to the tanks, and scratch or stain the plate emulsion as many plates are processed.

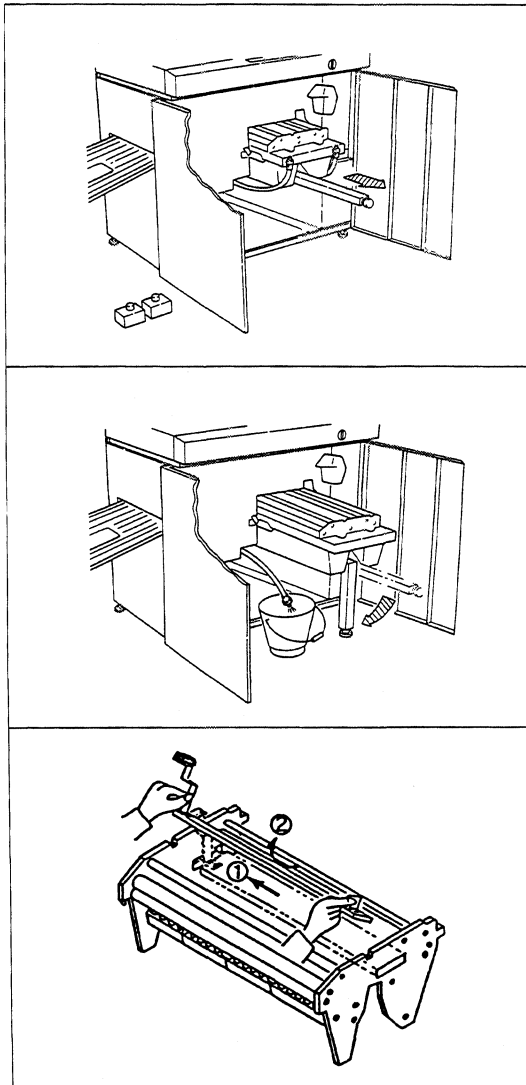

- (1) Turn off the POWER switch.
- (2) Open the front cover of the machine and move the whole processor forward.
- (3) Pull out the stand in the direction of the arrow.
- (4) Take up the replenisher containers.
- (5) Prepare a bucket for draining and extend the drain hose into the bucket.
- (6) After the processing tanks have been drained completely, return the drain hoses to their original positions.
- (7) Disconnect connector J18.
NB : Be very careful not to allow the connector to come in contact with water. If it should become wet, dry it completely before insertion.
- (8) Pull out the whole processor to a place convenient for cleaning.
- (9) Remove the conveyor unit from the tank unit and remove the anti-oxidation board carefully.

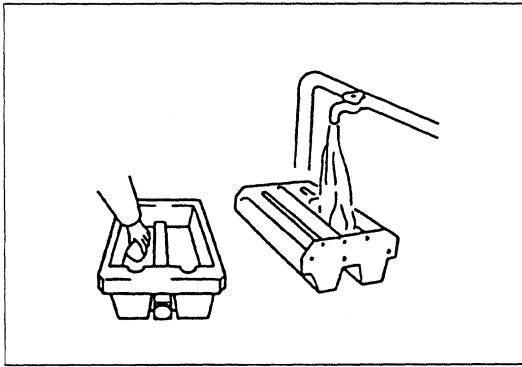

(10) Clean the tank unit and conveyor unit thoroughly with water.

Carefully wipe off any sediment with a damp cloth or sponge.

CAUTION : For cleaning the rollers of the conveyor unit, use water at a temperature of below 40°C (104°F). No detergent or polishing compound must be used.

9.2.2 Replacement of the cutter blade

The cutting capacity of a cutter blade is approx. 300 plates (about two 75m /2952.75" rolls).
Replace the blade at least once a month regardless of the number of cuts made.

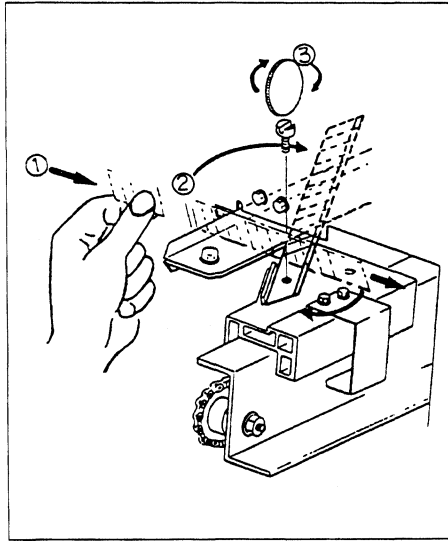



- (1) Turn off the POWER switch.
- (2) Open the front cover
- (3) Remove the cover of the cutter assembly.
- (4) Insert the cutter blade between the blade guides (upper and lower) and lock in its specified position.

NB1 : Be careful not to hurt yourself with the cutting edge.

NB2 : Use a commercial NT cutter blade (length 85mm /3.35").

NB3 : Place the back of the blade against the cutter carriage guide and tighten with the setscrew.





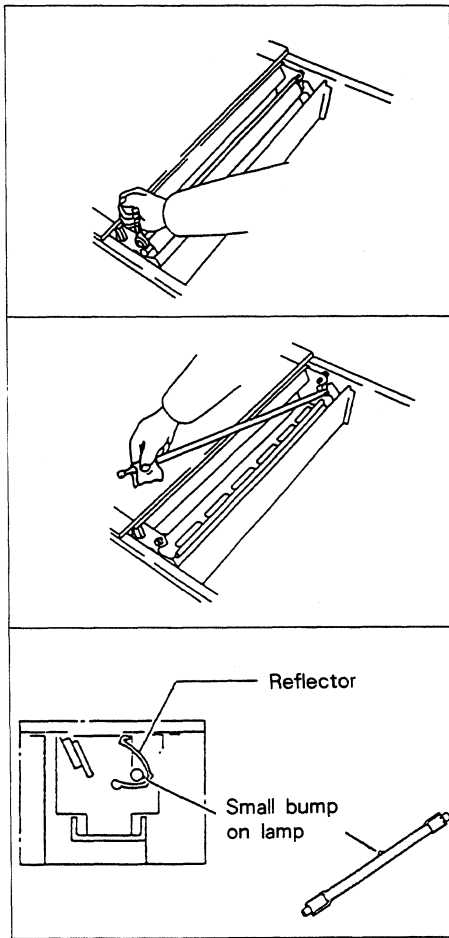

- (5) Turn on the POWER switch.
- (6) Check the cutting operation in the "STAND BY" state.  + 
- (7) Clear the "STAND BY" state.

9.2.3 Replacement of the halogen lamp

The machine uses a 130V, 1250W halogen lamp as the light source.





Always make sure that the lamp and the reflector have cooled before attempting to replace the lamp with a new one.

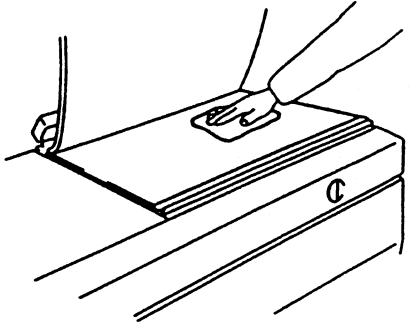
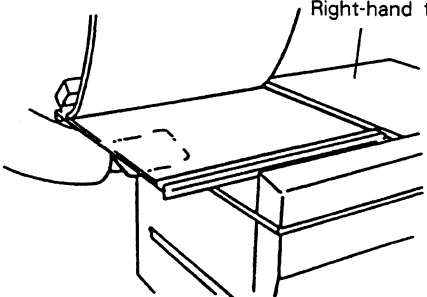

- (1) Set the "STAND BY" state and move the copy holder.  + 
- (2) Turn off the POWER switch.
- (3) Remove the right-hand top cover (M4 X 4).
Remove the reflector fastening screws (M4 X 2)
- (4) Hold the lamp with a clean dry cloth or wear gloves. Never hold it with bare hands. Be careful not to smear or fingermark the lamp surface. Such stains could cause uneven illumination as well as shorten the life of the lamp. If the lamp should be fingermarked or smeared, apply a very small amount of commercial alcohol to lens paper (available at general camera shops) and lightly wipe.
NB : The small bump on lamp and the reflector should face each other during replacement.
- (5) After the lamp has been replaced, turn on the POWER switch.
- (6) Set the STAND BY state and check to see if the new lamp lights up normally.
 +  The lamp lights for 5 sec.
- (7) Replace the reflector and the right-hand top cover as they were.
- (8) Return the copy holder to the home position.
 + 
- (9) Clear the STAND BY state.

9.2.4 Care of the copy glass

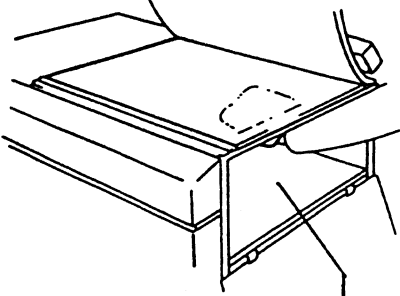
As the copy glass is liable to be stained by dust or fingermarks, check it at start-up every day. If stained, wipe it with a soft cloth using a glass cleaner (available on the market), taking care not to leave any cleaning agent behind.

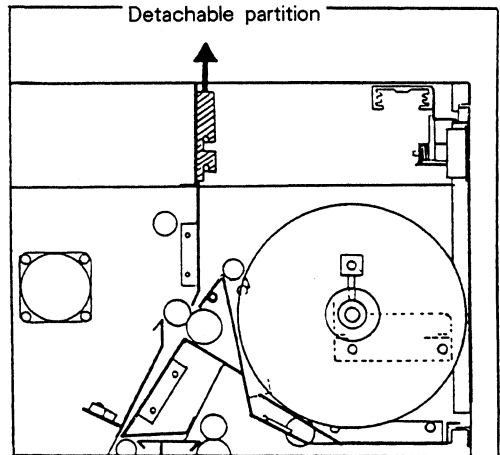
<p>I</p> 	<p>II</p>  <p>(1) Move the copy glass to the left in the STAND BY state.  + 2</p> <p>(2) Remove the right-hand top cover and pull out the detachable partition in the direction of the arrow. (see IV)</p>
<p>III</p>  <p>(1) Turn off the power once and turn it back on.</p> <p>(2) Move the copy glass to the right in the STAND BY state.  + 4</p> <p>(3) Replace the detachable partition and the right-hand top cover as they were.</p>	<p>IV</p> 

9.2.5 Lens-mirror assembly

The lens and mirror located in the lens-mirror assembly are not easily dirtied. Over time, however, their optical performances may deteriorate due to dust or other matter.

NB : Lightly clean once a month using an air brush.

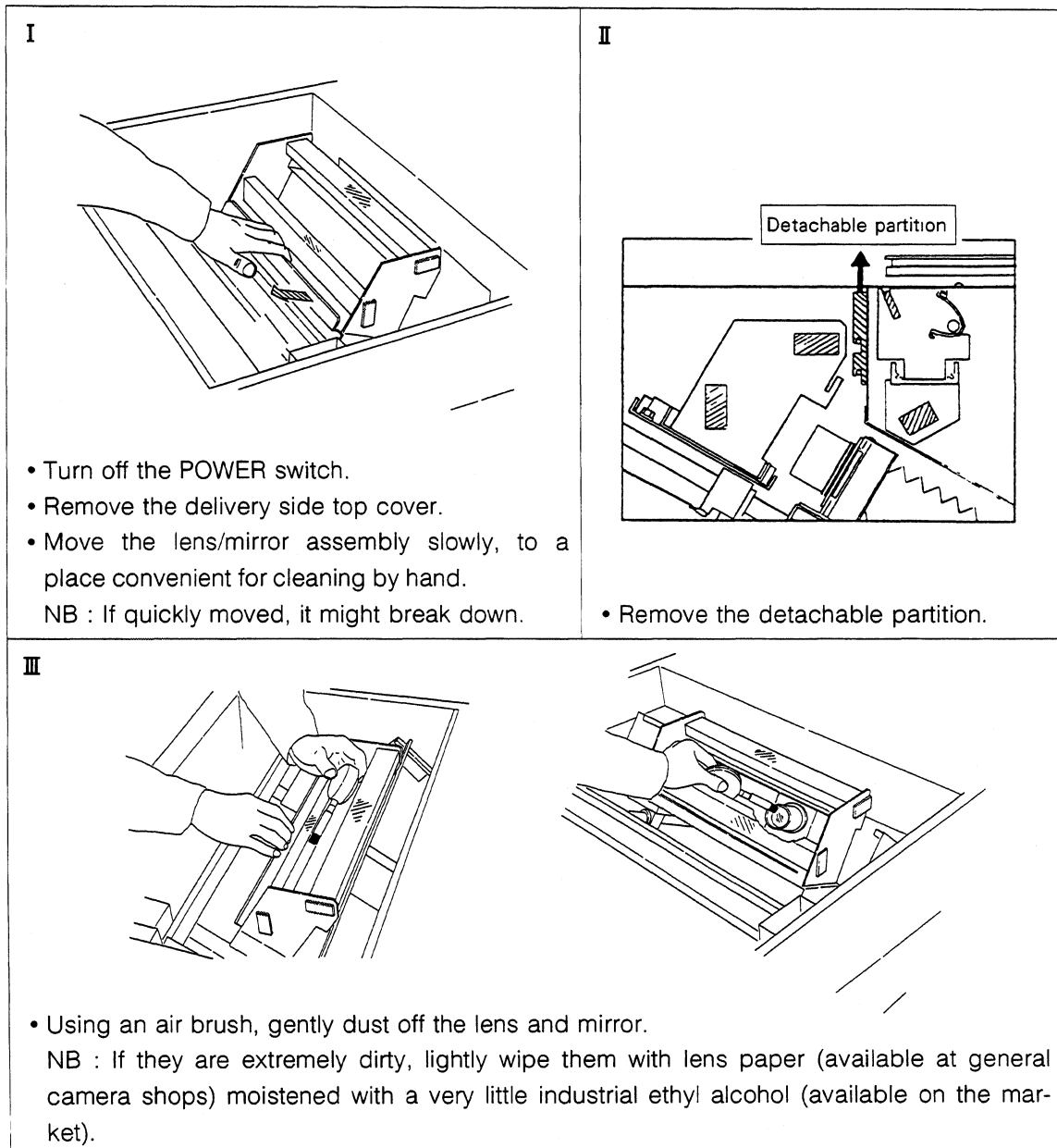

9.2.6 Cleaning the dryer inlet rollers

If the rollers in the dryer are dirty, the emulsion of the material can be scratched or stained.

NB : When replacing the Silver Master roll, clean the rollers.

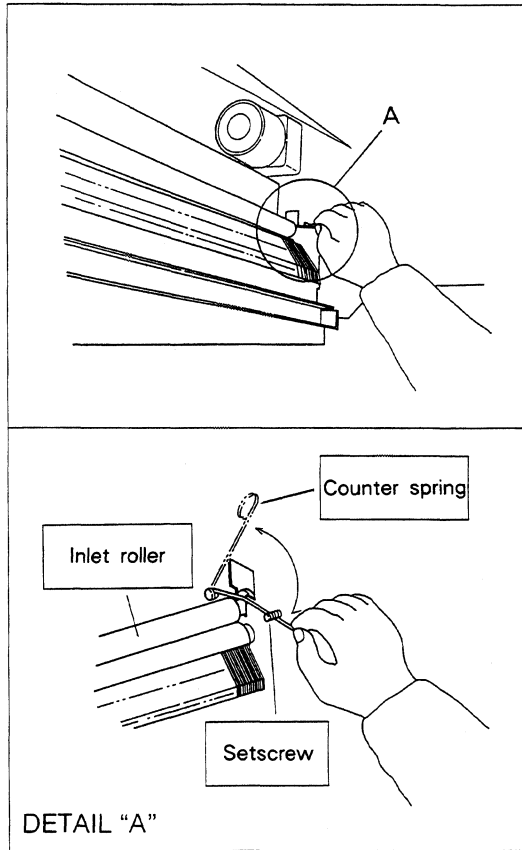

- (1) Turn off the POWER switch.
- (2) Open the machine front cover and remove the processor from the machine.
- (3) Release the counter spring at the dryer inlet roller (upper) by pulling from the setscrew in the direction of the arrow.
- (4) Remove the upper roller and clean it with a damp rag which has been lightly squeezed once.
- (5) Place back the rollers and counter springs.
- (6) Replace the processor itself as it was, and close the machine front cover.

9.3 Lubrication

The required frequency of lubrication depends on the frequency of operation. The following frequencies are recommended for the parts to be lubricated.

Note 1: For lubricating oil, use SHELLTHERUS #27 or equivalent - once a month

Note 2: Apply the thinnest possible coating of oil to them.

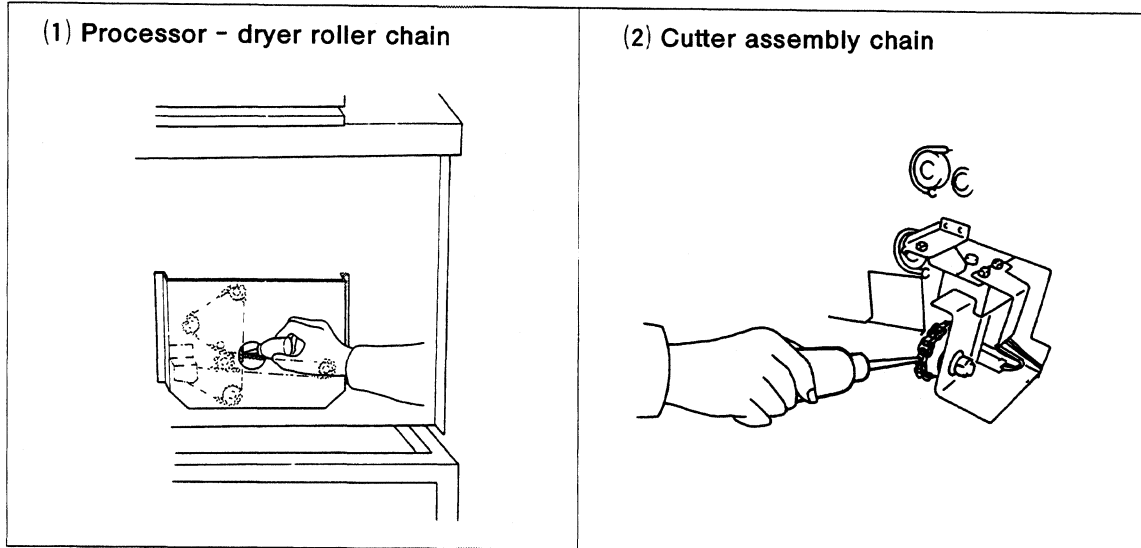

9.4 Order of Parts

The machine incorporates various kinds of parts. Some of them can be installed easily by the customers and others can be installed only by trained service personnel.

When ordering, please let us know the following:

- (1) Whether parts only are needed or both parts and installation (replacement) service are needed.
- (2) The information given in the certificate or the nameplate of your machine.
 - i) MODEL: CP-414V
 - ii) MFG NO.
- (3) Descriptions of parts and quantities required, data of delivery, etc.

NOTES : • Specifications are subject to change without notice.

- The manufacturer assumes no responsibility for any trouble caused by any modification made by the user or by the use of another company's equipment or parts with the machine without the manufacturer's approval.

10. TROUBLESHOOTING

10.1 Error Messages

If an error message appears, it means that the machine is in trouble.

Turn off the POWER switch once and allow at least 5 seconds before turning it back on, and retrying operation. If again the machine does not work normally, contact us.

Message	Error	Check Point
COPY POSIT	The copy holder is not at its home position while the power is on.	Turn the POWER switch off once then back on.
CUTTER ERR	The cutter is not at its home position while the power is on.	Turn the POWER switch off once then back on.
CUT CHECK	The exposed material is delivered without being cut.	Check the cutter for any nicked edge.
ERR 1	Cutting is not finished within a specified time.	1. Check cutter fitting. 2. Check cutter for a material jam. 3. Consult our service personnel.
ERR 2	The cutter won't return to its home position within a specified time.	1. Check cutter for a material jam. 2. Consult our service personnel.
ERR 3	The copy holder has gone to the travel end after the start key is pressed.	1. Consult our service personnel.
ERR 4	The roll in use cannot be rewound. The material will not reach the starting position.	1. Free the nip rollers (), and rewind the roll by hand. 2. Reset the roll. 3. Consult our service personnel.
ERR 5	The upper roll cannot be rewound.	1. Rewind the upper roll by hand. 2. Consult our service personnel.
ERR 6	The lower roll cannot be rewound.	1. Rewind the lower roll by hand. 2. Consult our service personnel.
ERR 7	Master does not feed.	Turn off the POWER switch immediately and consult our service personnel.
ERR 8	Master does not feed.	Turn off the POWER switch immediately and consult our service personnel.
ERR 9	The lens and mirror did not reach the prescribed position within a specified time.	Turn off the POWER switch immediately and consult our service personnel.
ERR 10	Master does not feed after the start key is pressed.	Turn off the POWER switch immediately and consult our service personnel.

11. AUTOMATIC REPLENISHMENT DEVICE

This system automatically replenishes the developing and stabilizing tanks with activator replenisher and stabilizer replenisher, respectively to ensure a prolonged service life for the solutions in the tanks.

11.1 Components

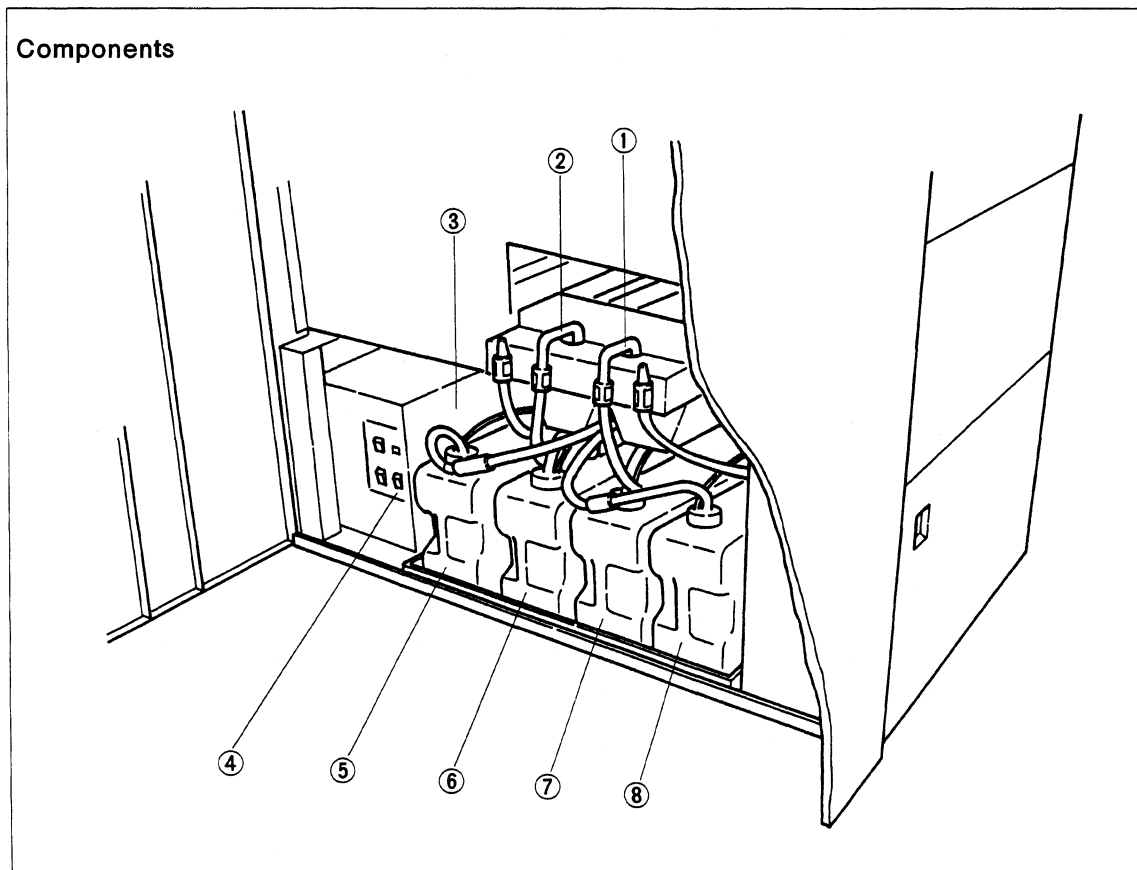

11.2 Control Panel

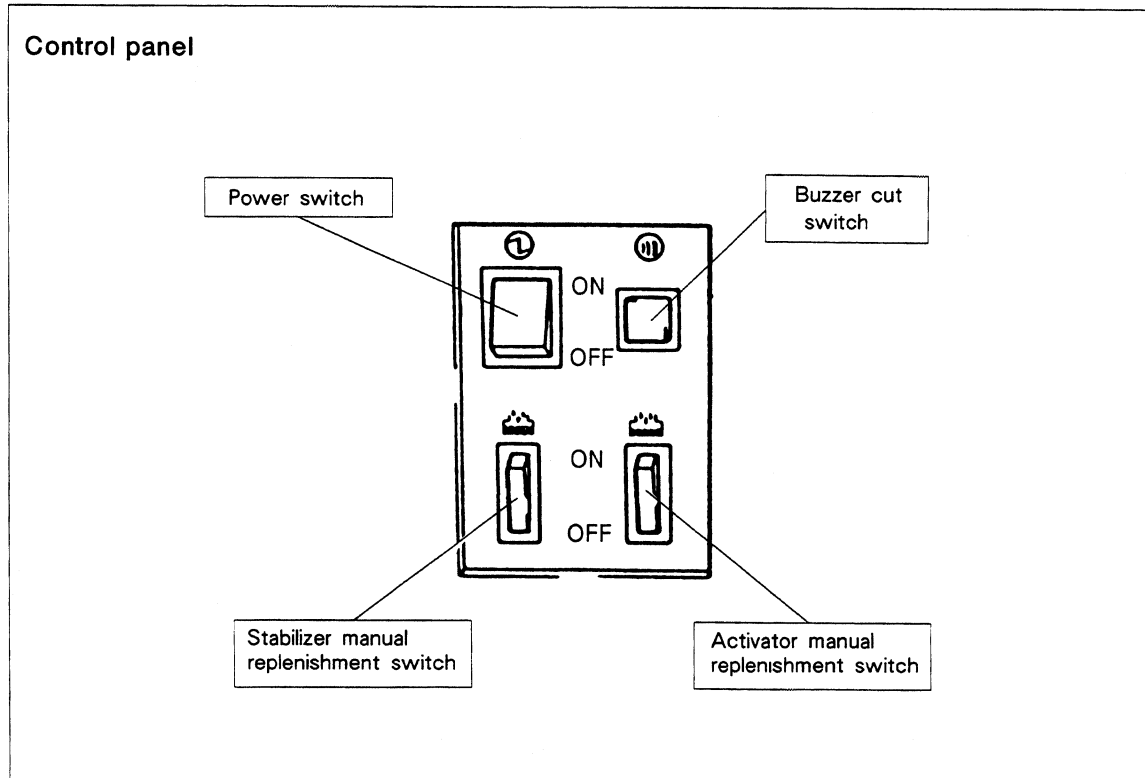

(1) Power switch

When this switch is turned on, the control circuit is activated and the device is ready for replenishment.

(2) Buzzer cut switch

When the replenisher or drain container sensor is activated, the buzzer sounds; the buzzer can be stopped by pressing this switch.

(3) Activator manual replenishment switch

Replenishment is done while this switch is held depressed.

(4) Stabilizer manual replenishment switch

Replenishment is done while this switch is held depressed.

11.3 Operating the Replenishment Device, and Changing Replenishment Time





11.3.1 Automatic replenishment mode

Each time the cumulative area of processed material calculated from the preset roll width and master length reaches 1 m², a replenishment of approx. 50cc is made (standard replenishment time 7 sec).

NB : Replenishment starts once the material has completely entered the developing tank, and the start key is invalid while the following message is on display.

REPL IN WAITING

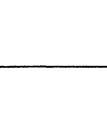
The device is factory set at standard replenishment time "7 sec."
To change the replenishment time, proceed as follows:

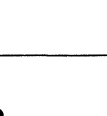
1) Press  while pressing.	 + 		
2) "REPL TIME?" and "07" (current input value) appear on the display.	<table border="1"><tr><td>REPL TIME?</td><td>07</td></tr></table>	REPL TIME?	07
REPL TIME?	07		
3) Enter the desired replenishment time using the numeric key pad. (e.g. 8 sec.)			
4) Press  to store it.			











CAUTION : Prior to changing the replenishment time, pour 10 liters of solution diluted in the ratio mentioned in 7.6(activator 1:1;stabilizer 1:3) into the respective containers.

11.3.2 Initial replenishment mode

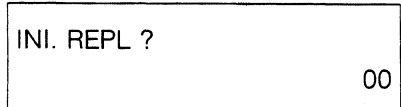
If the machine is out of use for a long period of time, the level of solution in the processor tank will fall due to evaporation.

Initial replenishment is made automatically for the preset time to maintain the proper level of solution each time the POWER switch is turned on.

To set or change the replenishment time, proceed as follows:

1) Press  while pressing	 +   
2) "INI. REPL?" and "00" appear on the display.	
3) Enter the desired replenishment time using the numeric key pad. (e.g. 5 sec.)	 
4) Press  to store.	 

11.4 Control of Activator Level

When the level of activator in the processor tank is below a certain level, the following message will appear on the display and the processing solution will be automatically refilled.

NB: The machine can not be started during replenishment.

REPL IN

WAITING

If the level of solution does not rise after replenishment is started, replenishment is stopped, and the following message (accompanied with the sounding of the buzzer) will appear on the display.

CHECK

PROCESSOR

Inspection Procedure:

1. Remove the front cover of the machine.
2. Slide the tank out towards you. Then make sure the level sensor moves up and down normally and the hose is properly connected and not folded.
3. Close the front cover of the machine and check that replenishment is being made properly.

REMARKS:

Please contact our service engineer if replenishment is not being carried out properly.

MITSUBISHI PAPER MILLS LIMITED

Head office: Shin-Nisseki Bldg., 7th Floor
No. 4-2, Marunouchi 3 chome, Chiyoda-ku, Tokyo, Japan
Tel Tokyo(03)3213-3742

Mitsubishi Paper International, Inc.:
520 Madison Avenue New York, N. Y 10022 U.S.A. Tel.212-980-9644
Mitsubishi Paper GmbH:
Kennedydamm 19 4000 Düsseldorf 30 West Germany Tel.0211-4397-215

CP-414V

Installation Manual

Installation Environment

- Choose a location with good year-round ventilation, a temperature between 10° C and 30° C, and a humidity between 40% and 70%.
- Avoid locations with direct sunlight.
- Power supply is 1ø200/220/240 V, 2.5 KW, 14 A. Wiring should be able to sufficiently withstand this load and variance should be kept within ±10%.

※ Connect to a power supply that has an earth leakage breaker.
Power connection should be handled by a qualified electrician.

※ Be sure to ground properly in accordance with standard safety procedures.

- Provide at least 40 cm of space behind the unit for servicing.
- Install on a level floor that is able to withstand a weight of 230 K.
- Avoid locations that are subject to vibration.

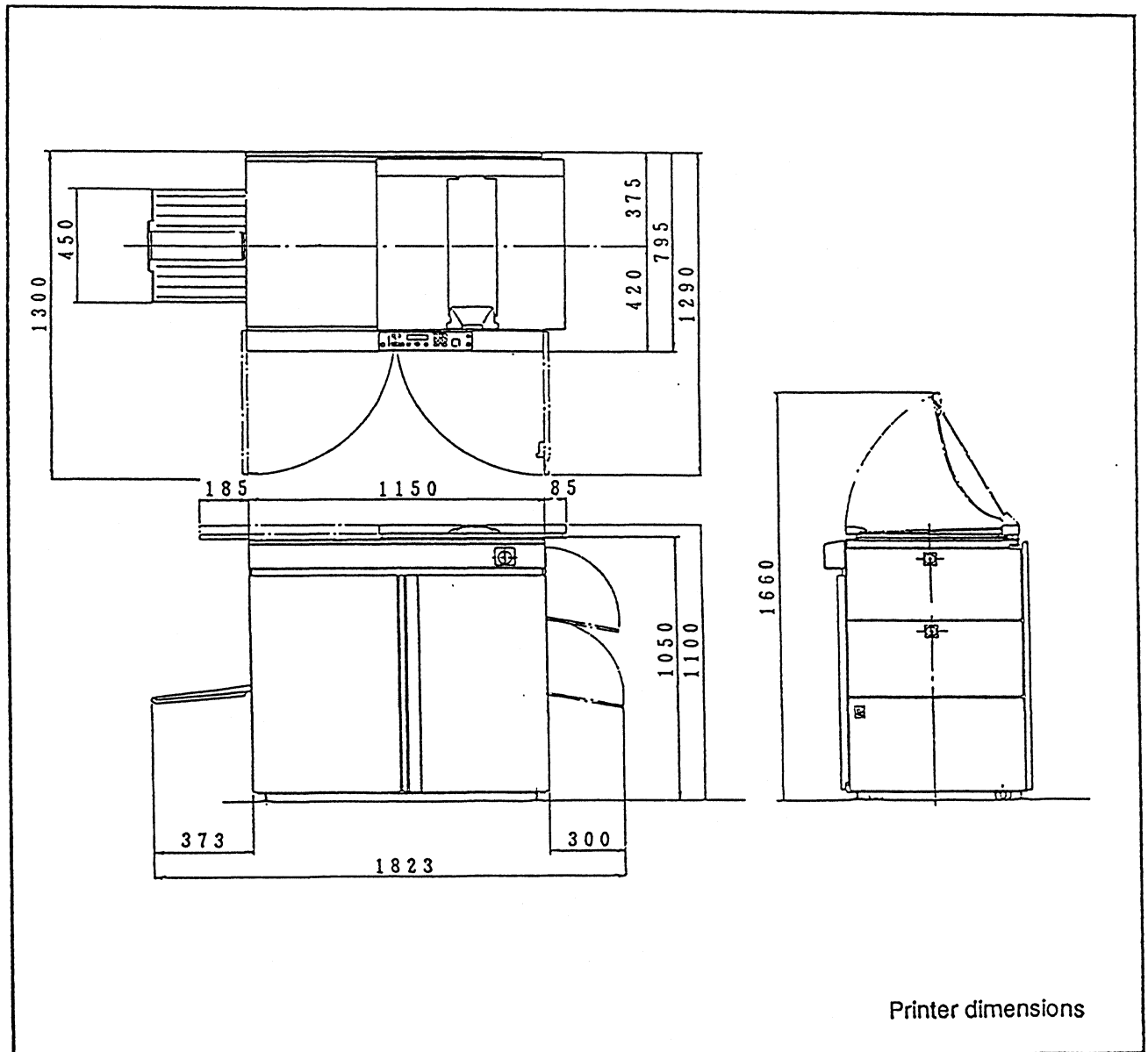

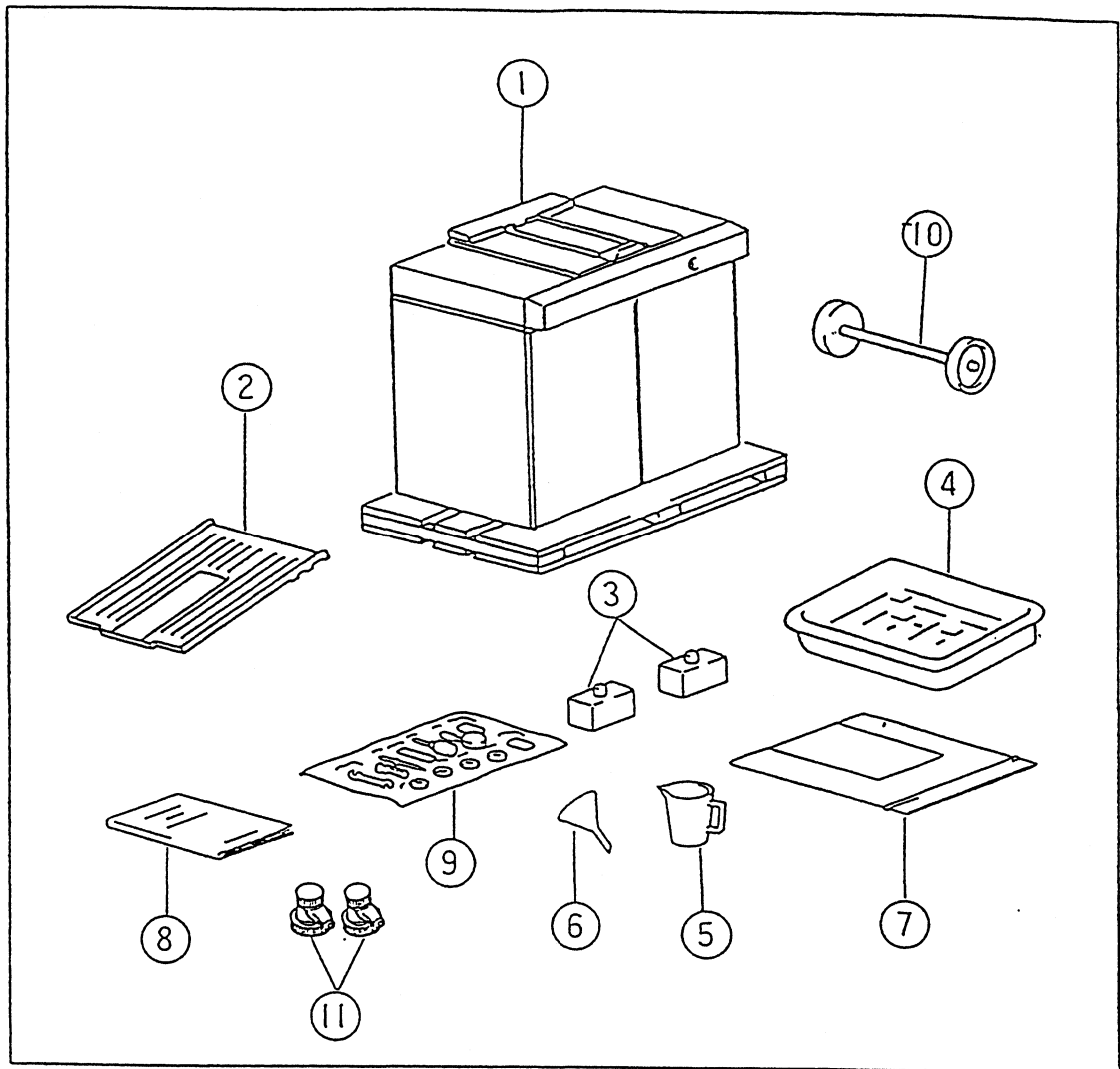

Packing list

(Confirm when unpacking.)

	Name	Qty.
1	Body	1
2	Master discharge tray	1
3	Replenishment bottle	2
4	Drip vat	1
5	Measuring cup	1
6	Funnel	1
7	Test chart & sample	1 set
8	Instruction Manual and Technical Guide	1 set
9	Spare parts	1 set
10	Spools (x 2) & spool shaft	2 sets
11	B cock	2

Spare parts list

	Name	Qty.
1	Screwdriver set	1 set
2	Leg bases	4
3	Wrench	1
4	Cutter knife	1
5	Oiler	1
6	Blower brush	1
7	Screws and bolts	2 ea.
8	Glass fuses (1A-250 V, 2A-250 V, 4A-250 V, 6A-250 V)	1 ea.
9	Ceramic fuses (15A-250 W)	4 ea.
10	Temperature fuses -for dryer (with round tip) -for lamp (with connector)	1 set

Installation Procedure

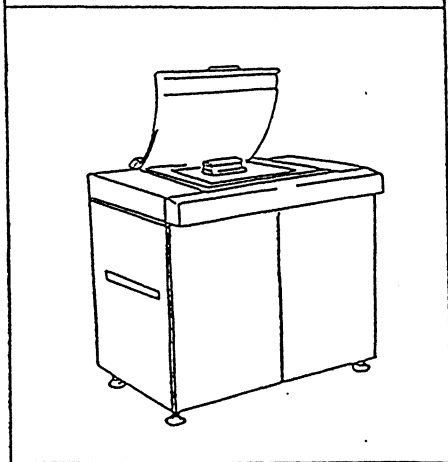
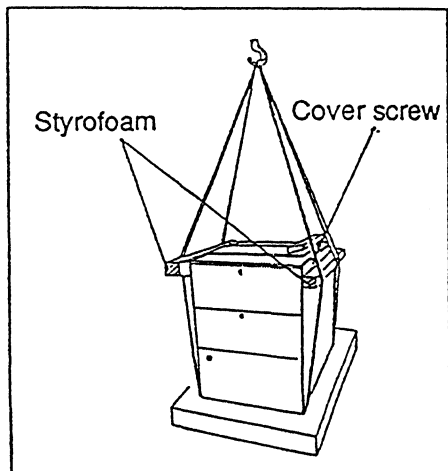

1. Remove the packaging from the body.

2. Remove the brackets that secure the pallet and the main unit.

※There are four brackets.

3. Place Styrofoam blocks on both sides and hoist the main unit using nylon rope.

The rear styrofoam block should be placed about 50 mm below the rear cover screw.

※Be sure to use nylon rope that is at least 6 m in length.

※Be sure to suspend the outer side by the adjustment bolt.

4. Move the unit over to the location of installation and place on the leg bases provided.

Do not move the copy section with your hand. If you do, make sure to loosen the drive belt. See page 7 for loosening the copy drive belt.

※Caster wheels are provided beneath the unit for easy moving.

5. Place a sheet of clean paper on the copy glass. Place a level on the paper and adjust the unit with the adjustment bolts so that it is level.

6. Open the front cover and remove the processor unit.
7. Remove the transfer unit and clean the developing and fixing tanks.
8. Replace the processor unit and place the drip vat under the body.
9. Install the cutter blade.

Preparing Solutions

1. Mix the developer and fixer according to the details given in the instruction manual. Pour the solutions into the tanks and replenisher bottles.
2. Place the replenisher bottles containing the prepared solutions at each unit.

Connecting the Power Supply

1. Check that the power switch is off.
2. Connect the input wire to the power supply. The power supply must have an earth leakage breaker.

Removing the Securing Brackets and Connecting the Connectors

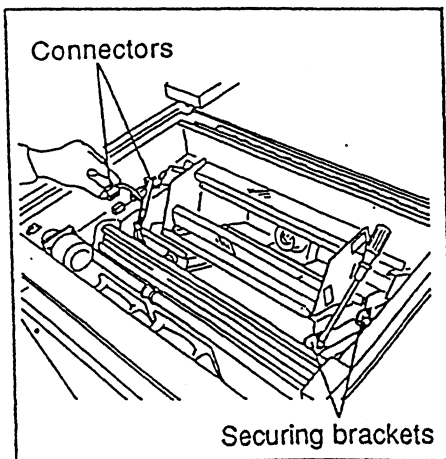

1. Turn on the power switch and return the copy frame to its specified position.
2. Turn off the power switch.
3. Remove the top cover on the paper discharge side. Remove the lens frame and the mirror frame securing brackets (yellow).
 - ※Do not touch the lens or mirror.
4. Connect the connectors (J3 and J4).
5. Remove the lens cap and install the upper cover of the paper discharge side.

Inspection and Adjustment

1. Open the left front door of the body and remove the cover for the CPU board on the right hand side. Adjustments are made by the DIP switches on the CPU board.

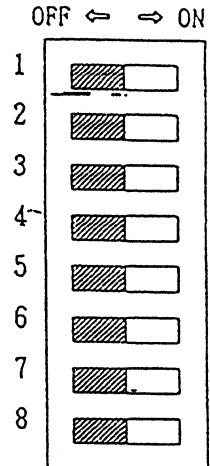
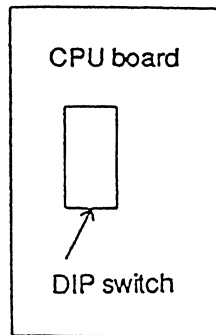

DIP switch settings

No.	Item	Use	Normal setting
1	Data input	Used with DIP switch 5 for changing data in each compensation mode and for inputting.	OFF
2	Frequency selection	Selects between 50 Hz and 60 Hz. ON: 50 Hz, OFF: 60 Hz	ON/OFF
3	Inch/millimeter selection	Selects the unit system for feeding the master. ON: inch, OFF: millimeter	ON/OFF
4	Repeated running	Used for repeated running of a series of operations. Start by <input type="checkbox"/> key, stop by <input type="checkbox"/> key.	OFF
5	Data display	Used for the display and confirmation of currently input basic data.	OFF
6	Language selection	Selects display format. ON: English, OFF: Japanese	ON/OFF
7	Replenisher unit	Used when replenisher unit (option) is attached.	OFF
8	Initial reset	-By putting ON, the exposure value and exposure length are initialized when power is turned on. -By this DIP switch ON together with DIP 1, the compensation value is also initialized when the power is turned on.	OFF

2. Select the frequency so that it matches the local frequency.

50 Hz: set DIP switch 2 to ON.

60 Hz: set DIP switch 2 to OFF.

3. Select the system of measurement (inches or millimeters).

Inch: set DIP switch 3 to ON.

Millimeter: set DIP switch 3 to OFF.

4. Turn on the power switch.

5. Set the master plate as instructed in the instruction manual.

6. Carry out final assembly and checks.

a. Attach the covers.

b. Check the series of operations described in the instruction manual.

c. Do a test exposure using the test chart.

d. Check the distance between the diagonally opposite corners.

7. Check and adjust the distance between diagonally opposite corners.

This adjustment is done thoroughly before shipping. However, if one of the distances between diagonally opposite corners is greater, check and make adjustments according to the following procedure.

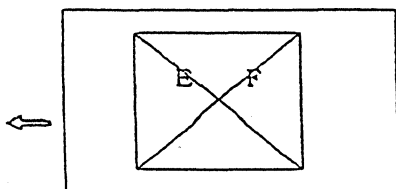

1) Place a suitable original such as a test chart (drawn with grid lines) or a scale on the copy glass.

2) Expose and measure the distances E and F between the diagonally opposite corners. The tolerance should be within 0.5 mm.

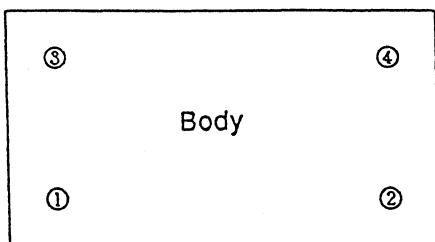

Operation side

If E is greater than F:

•Either lower adjusting bolt ① at the base of the body, or raise adjusting bolt ②.

If F is less than E:

•Either raise adjusting bolt ① at the base of the body, or lower adjusting bolt ②.

※The height of the body can be increased or decreased by about 1 mm with one full turn of the adjusting bolt.